

# winflex®

Flexible grid coupling



Au service de votre monde industriel

**DS TECH**

Drive System Technology

1275 Newton, local 15  
Boucherville, Qc,  
Canada, J4B 5H2

(450) 655-7447  
info@pt-dstech.com  
www.dstech.ca



# Winflex couplings:

the best cost-effective and reliable solution, years of use to achieve and to prove this fully optimised coupling!

## The hub

- Thanks to the very special design of the teeth, the contact surface between the grid and the hub teeth increases proportionally to the torque to keep the same contact pressure at any time.
- As contact is on numerous teeth, this efficiently absorbs the torque thus avoiding damage.
- No resulting reaction forces on shafts.

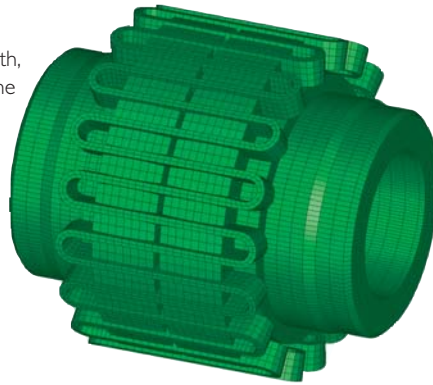

## The grid

- The grid always works in the direction of the material, within its elastic field.
- A new surface treatment prevents oxidation, friction and wear.
- The grid has been manufactured to ensure durability.

Normal load

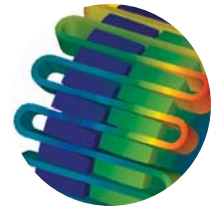

Heavy Shocks

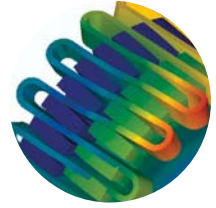

and Excessive Overloads





# A complete range!

Only one grid for each execution of the same size

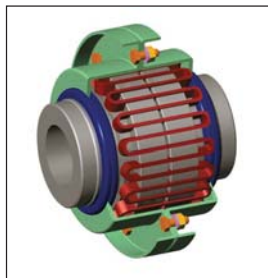

**T.TL.TL2**  
 Vertical or Horizontal  
 Position

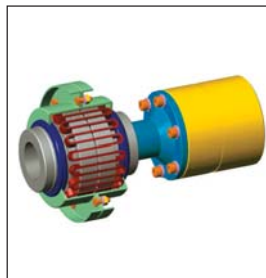

**T.TL.NPE**  
 Spacer type

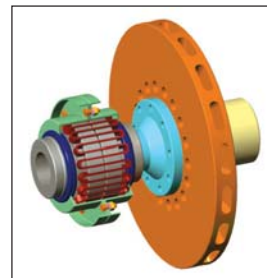

**TDF**  
 Disc brake type

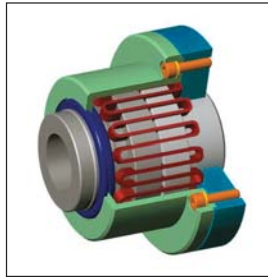

**BSAT**  
 Single cover type

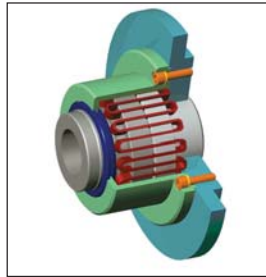

**BSA**  
 Single cover type for  
 Flywheel, pulley application  
 etc...

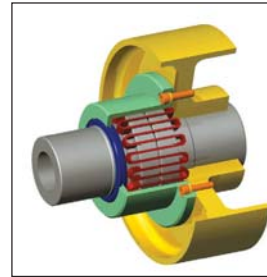

**CPF**  
 Brakewheel type

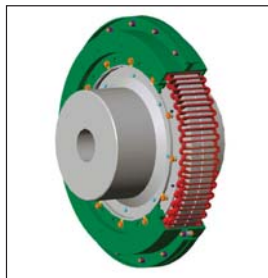

**S**  
 Heavy duty type

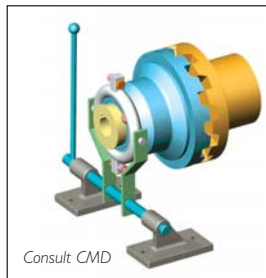

Consult CMD

Overrunning clutch

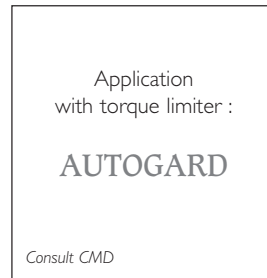

Application  
 with torque limiter :

**AUTOGARD**

Consult CMD

## Selection

### 1) DETERMINE THE CALCULATED TORQUE

$$\text{Calculated Torque (Nm)} = \text{Absorbed Torque (Nm)} \times \text{SF} = \frac{9550 \times \text{Absorbed power (kW)} \times \text{SF}}{\text{Speed (rpm)}}$$

Selection of Service Factor SF: see table below.

### 2) SELECT

The size of coupling whose rated torque is equal or higher than the calculated.

### 3) CHECK

That selected coupling is compatible with speeds and bores as mentioned on the tables.

APPLICATIONS	SF	APPLICATIONS	SF
<b>AGITATORS *</b>	1	<b>LUMBER INDUSTRY</b>	
		Circular rip saw	1.75
<b>CEMENT INDUSTRY</b>		Ban rip saw	1.5
Balls and rods	2	Edger, Head rig Hog	2
Hammer mill or hog	1.75	Log haul	2
Grizzly	2	Rolls, reversing	2
		Trimmer	1.75
<b>COMPRESSORS</b>		<b>MACHINE TOOLS</b>	
Centrifugal	1	Miscellaneous, auxiliary*	1
Rotary	1.25	Notching press	1.75
Reciprocating (1 cylinder, single acting)	3	Planer	1.75
“ (1 cylinder, double acting)	3	Main drive	1.5
“ (2 cylinder, single acting)	3		
“ (2 cylinder, double acting)	3	<b>PAPER INDUSTRY</b>	
“ (3 cylinder, single acting)	3	Calender	1.75
“ (3 cylinder, double acting)	2	Super-calender	1.75
“ (4 cylinder more, single acting)	1.75	Line shaft	1.5
“ (4 cylinder more, double acting)	1.75	Cylinder, dryer, couch, press	1.75
<b>CRUSHERS</b>		Chipper	2.5
Minerals	2.5	Reel, rewinder, winder	1.5
Stone	2.5	Beater, pulper	1.75
<b>CONVEYORS</b>		Jordan	2
Belt/screw conveyors	1	Barking drums (final gearing machined)	2
Apron conveyors	1	Barking drums (cast teeth gear)	2
Scraper	1.5	Felt stretcher	1.25
Buckets conveyors	1.25	<b>PUMPS</b>	
<b>CRANES, HOISTS, ELEVATORS*</b>		Centrifugal	1
Main hoist	1.75	Gear. Rotary or vane	1.25
Bridge, travel or trolley	1.75	Reciprocating (1 cyl. Dble or single act)	3
Mach, tools, warehouse	2	“ (2 cyl. Dble act)	1.75
Grab-buckets, casting, scraps	2.5	“ (3 cyl. Dble act)	1.5
Filler, pits, strips, ingots	2.5	<b>RUBBER INDUSTRY</b>	
Cranes for general handling	1.75	Calender	2
Cranes for harbor and grab-buckets	2.0	Mixer (Banbury-Werner)	2.5
<b>FANS</b>		External mixer, mixing mill	2.5
Blowers centrifugal*	1	Super calender	2.5
Cooling tower fan	2	<b>STEEL WORKS</b>	
Forced draft with slip clutch*	1	Draw bench, wire drawing	2
Induced draft with damper control	1.25	Coilers, uncoilers (at max.torque)	1.5
Induced draft without control	2	Strengtheners flattening	2
<b>FLOUR MILLING</b>		Wire mills	2
Various type	1.75	Rod mills	2.5
<b>FOOD INDUSTRY</b>		Feed rolls, Blooming mills	3
Beet slicer	1.75	Tube conveyor rolls	2
Bottling, can filling mach	1	<b>SUGAR INDUSTRY</b>	
Cookers, continuous duty	1.25	Cane knife and crusher	2
<b>GENERATORS</b>		Mill stands turbines driven with helical gears	1.5
Even load	1	Mill stands turbines driven with any other prime mover	2
With overload	2	<b>TEXTILE</b>	
Welder load	2	Miscellaneous	1.5
A.C dynamo with hyd. turbine*	1	Calender, Card machine	1.5
		Printing cylinder	2
		<b>WOOD WORKING MACH.</b>	
		Miscellaneous	1.25

\* Only Applicable to installations with Maximum Torque less than 1.5 x Coupling Basic Torque.

## Type T - TL - TL2 Horizontal or Vertical Working position

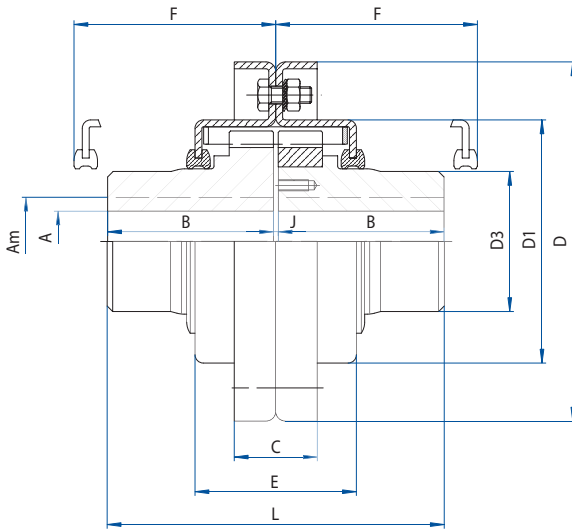

Hub Z to 16

Hub 28 to 95

F: Clearance for grid spring assembly and removal

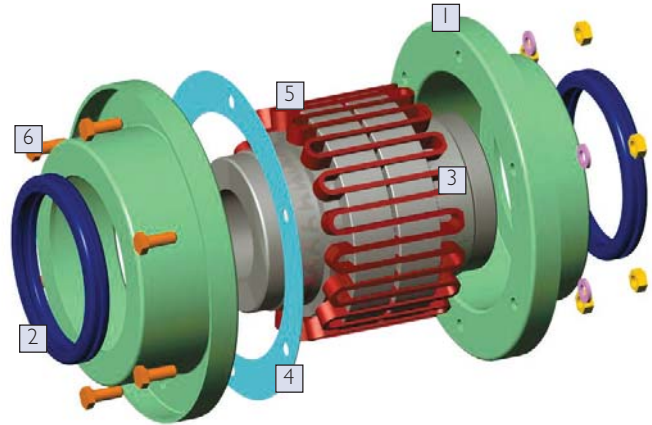

Item	Designation
1	Halfcover
2	Seal
3	Hub
4	Gasket
5	Spring
6	Bolts & Screws

SIZE	Z	000	00	0	1	2	5	9	16	28	43	70	95
<b>Nominal Torque (Nm)</b>	<b>90</b>	<b>190</b>	<b>380</b>	<b>950</b>	<b>1900</b>	<b>3800</b>	<b>8500</b>	<b>12500</b>	<b>24000</b>	<b>48000</b>	<b>70000</b>	<b>120000</b>	<b>160000</b>
Am	Keyway	28	38	55	55	80	110	105	130	180	230	230	270
	Shrink fit	-	-	45	45	60	100	90	110	170	200	220	250
A	Rough bore	-	-	-	-	-	30	30	60	75	85	95	105
B**	T	50	60	60	60	80	80	110	110	130	155	180	200
	TL,TL2	-	-	-	110	110	170	195	195	225	260	280	300
C	20	30	30	30	30	30	36	36	42	44	50	50	50
D	92	130	158	165	200	250	265	307	395	494	595	595	670
D1	68	88	113	120	154	203	212	253	330	427	522	528	598
D3	39	51	76	76	110,5	158	146	183	253	330	330	330	380
E	57	58	58	77	77	78	123	123	124	125	125	200	206
F	58	59	59	78	78	79	125	125	125	126	126	201	201
J	2 <sup>+1</sup> <sub>-0,5</sub>	2 <sup>+1</sup> <sub>-0,5</sub>	2 <sup>+2</sup> <sub>-0,5</sub>	2 <sup>+2</sup> <sub>-0,5</sub>	3 <sup>+1</sup> <sub>-1</sub>	3 <sup>+1</sup> <sub>-1</sub>	3 <sup>+1</sup> <sub>-1</sub>	3 <sup>+1</sup> <sub>-1</sub>	3 <sup>+1</sup> <sub>-1</sub>	4 <sup>+2</sup> <sub>-2</sub>	4 <sup>+2</sup> <sub>-2</sub>	4 <sup>+2</sup> <sub>-2</sub>	4 <sup>+2</sup> <sub>-2</sub>
L (type T)	102	122	122	122	163	163	223	223	263	314	364	404	464

Weight type T (kg)	1.84	3.7	6.6	7.8	16.6	31	42	63	125	245	327	409	579
§ Solid hub type T (kgm <sup>2</sup> )	0.0011	0.0037	0.0105	0.0135	0.04	0.14	0.20	0.45	1.5	4.65	8.25	11.5	20.25
Max. speed (Rpm)	Without balance	4500	4500	3650	3450	2640	1880	1880	1570	1200	920	750	650
	Dynamically Balanced	-	-	4500	4500	4000	3600	3200	3000	2500	2000	1500	1250

\*\*Types: T = 2 short hubs  
TL = 1 short hub, 1 long hub  
TL2 = 2 long hubs

The contents of this bulletin are subject to change without notice.

## Type T - TL NPE

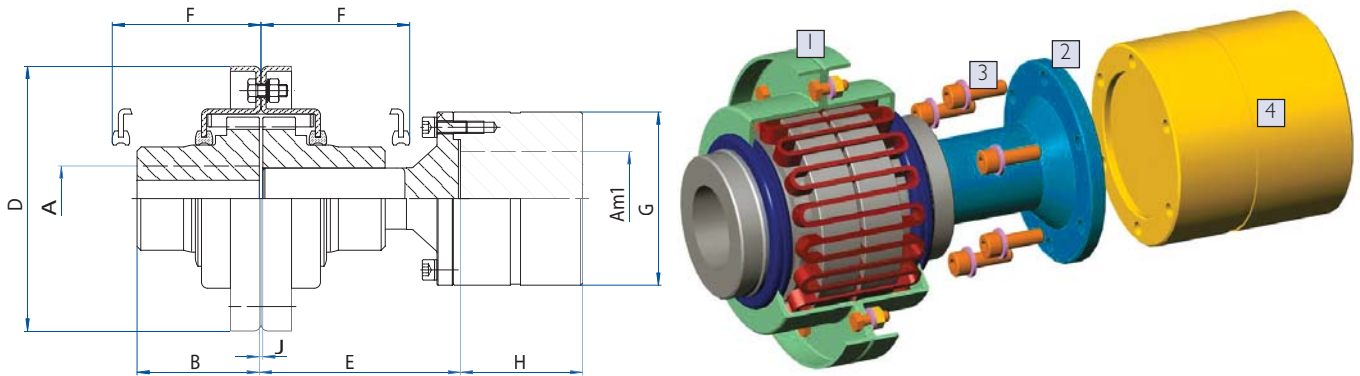

F: Clearance for grid spring assembly and removal

Item	Designation
1	Winflex
2	Spacer
3	Screws
4	Rigid hub

SIZE	Z	000	00	0	1	2	5	9	
<b>Nominal Torque (Nm)</b>	<b>90</b>	<b>190</b>	<b>380</b>	<b>950</b>	<b>1900</b>	<b>3800</b>	<b>8500</b>	<b>12500</b>	
Am keyway	28	38	55	55	80	110	105	130	
Am1 keyway	42	48	65	65	90	120	120	140	
B*	T	50	60	60	60	80	80	110	110
	TL	-	-	-	110	110	110	170	195
D	92	130	158	165	200	250	265	307	
F	58	59	59	78	78	79	125	125	
G	75	85	107	107	156	185	185	230	
$J_0^{+0,3}$	3	3	4	4	4	4	4	4	
H	60   80	60   110	80   110   140	80   110   140	110   140	140   170   210	140   170   210	170   210	
E	80 to 160	80 to 160	80 to 200	100 to 180	110 to 190	140 to 210	160 to 210	180 to 250	

Weight (kg) type T Being average for E and H	4	7	13	14.5	33.7	58.5	69	97
$J$ (kgm <sup>2</sup> )** Being average for E and H	0.0025	0.0075	0.0225	0.025	0.1	0.3	0.3	0.85
Max speed (Rpm)	Without balance	3600	3600	3000	2400	1700	1700	1500
	Dynamically balanced	-	-	-	3600	3600	3000	3000

\*Types: T = 2 short hubs  
TL = 1 short hub + 1 long hub  
\*\*Solid hub type T

The contents of this bulletin are subject to change without notice.



## Type TDF for Disc Brake Application

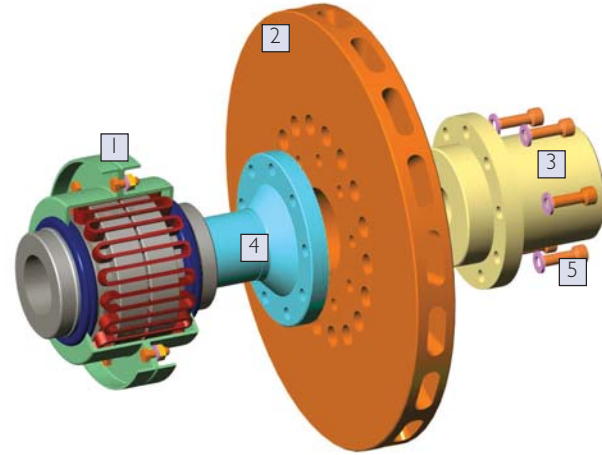
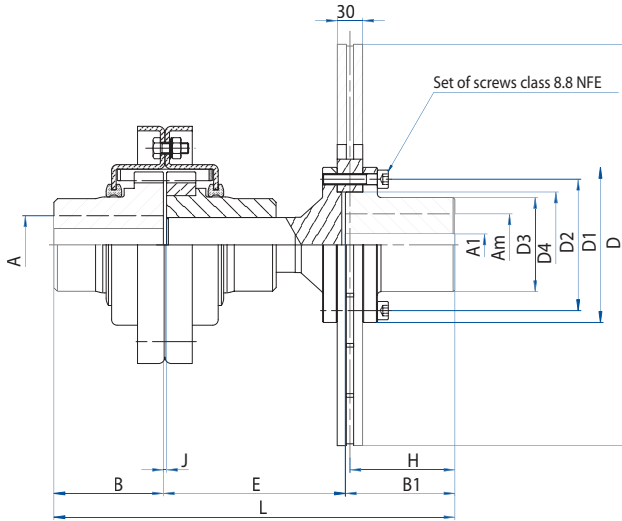

Item	Designation
1	Winflex
2	Disc brake
3	Rigid hub
4	Spacer
5	Screws

Coupling with ventilated disc brake,  
Designed to permit mounting and dismounting of the disc  
Without necessity of moving connecting machines.

SIZE	0		1		2				5					9			16		
<b>D</b>	315	355	395	395	445	445	495	550	625	495	550	625	705	795	625	705	795	795	
<b>Maximum Peak Torque (Nm)</b>	950		1900		3800				8500					12500			24000		
Am	Keyway fitting	55	55	55	80	80	110	110	110	110	105	105	105	105	105	130	130	130	180
	Shrink fit	45	45	45	60	60	100	100	100	100	90	90	90	90	90	110	110	110	170
AmI	Keyway fitting	55	70	75	75	80	80	110	110	120	110	110	120	135	150	120	135	150	150
	Shrink fit	50	60	70	70	70	70	100	100	105	100	100	105	120	135	105	120	135	135
A1	-	-	-	-	-	-	30	30	30	30	30	30	30	30	30	30	30	30	
B	60	60	60	80	80	80	80	80	80	110	110	110	110	110	110	110	110	130	
B1	107	107	107	107	140	140	140	140	140	140	140	140	140	140	140	140	140	140	
D1	124	145	165	165	175	175	218	218	238	218	218	238	268	300	238	268	300	300	
D2	105	125	140	140	146	146	190	190	205	190	190	205	230	260	205	230	260	260	
D3	82	100	110	110	112	112	155	155	168	155	155	168	190	216	168	190	216	216	
D4	85	105	115	115	120	120	160	160	170	160	160	170	195	220	170	195	220	220	
Number of Screws	9	9	9	9	12	12	12	12	12	12	12	12	12	12	12	12	12	12	
Set screws diameter	M10	M12	M14	M14	M16	M16	M18	M18	M20	M18	M18	M20	M22	M24	M20	M22	M24	M24	
Tightening Torque (Nm)	49	86	135	135	210	210	290	290	410	290	290	410	550	710	410	550	710	710	
$J_0^{+0,3}$	4	4	4	4	4	4	4	4	4	4	4	4	4	4	4	4	4	4	
E	117	115	115	115	115	115	127	127	127	162	162	162	162	167	169	169	169	187	
L	284	282	282	302	335	335	347	347	347	412	412	412	412	417	419	419	419	457	
X	102	102	102	102	135	135	135	135	135	135	135	135	135	135	135	135	135	13	

Weight (kg) with Rough bore*	15.2	18.2	20.5	29.7	31.7	44	61.5	61.5	67.5	74	74	80	90	105	103	111	125	187
↓ Solid hub type T (kgm <sup>2</sup> )*	0.02	0.03	0.04	0.07	0.08	0.17	0.27	0.27	0.33	0.33	0.33	0.40	0.51	0.70	0.65	0.76	0.95	2

Check that Maximum Peak Torque is larger than installation Peak Torque

\* Without Disc

The contents of this bulletin are subject to change without notice.

## Type BSAT - BSATL - BSATL2

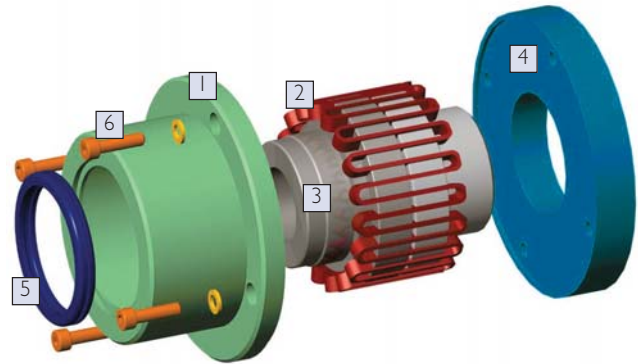
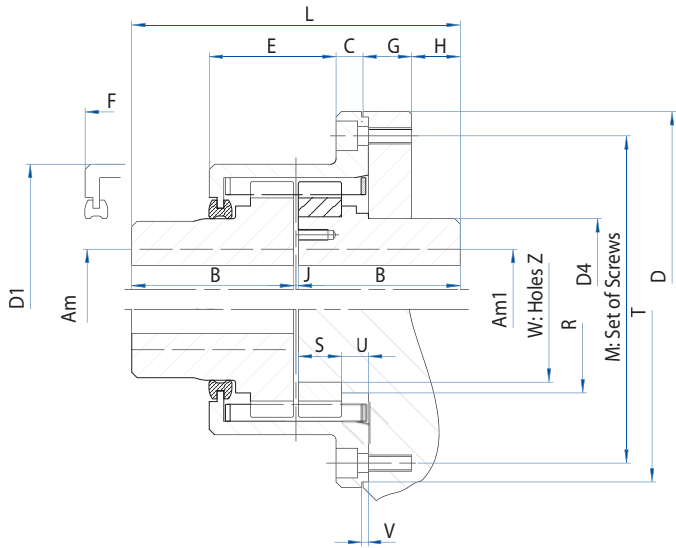

Item	Designation
1	Cover
2	Spring
3	Hub
4	Flange
5	Seal
6	Screws

Suitable mounting of pulley or flywheel  
F: Clearance for grid spring assembly and removal

SIZE	0	1	2	5	9	16	28	43	70	95
<b>Nominal Torque (Nm)</b>	<b>950</b>	<b>1900</b>	<b>3800</b>	<b>8500</b>	<b>12500</b>	<b>24000</b>	<b>48000</b>	<b>70000</b>	<b>120000</b>	<b>160000</b>
Am Keyway	55	80	110	105	130	180	230	230	230	270
Am I Keyway	50	75	110	100	120	180	230	230	230	270
Am shrink fit for hub without flange	45	60	100	90	110	170	200	220	220	250
B	T	60	80	80	110	130	155	180	200	230
	TL, TL2	110	110	110	170	195	195	225	280	300
C	13.5	13	13	19	22	27	11	10	11	13
D	170	205	250	286	340	425	515	616	630	700
D1	127	162	209	222	266	344	440	536	545	615
D4	75	109	157	145	182	250	326	326	326	376
E	62	62,5	62,5	102	99	94	112	113	188	187
F	120	120	120	187	187	187	187	187	314	315
J	2 <sup>+2</sup> <sub>-0,5</sub>	3 <sup>+1</sup> <sub>-1</sub>	3 <sup>+1</sup> <sub>-1</sub>	3 <sup>+1</sup> <sub>-1</sub>	3 <sup>+1</sup> <sub>-1</sub>	3 <sup>+1</sup> <sub>-1</sub>	4 <sup>+2</sup> <sub>-2</sub>	4 <sup>+2</sup> <sub>-2</sub>	4 <sup>+2</sup> <sub>-2</sub>	4 <sup>+2</sup> <sub>-2</sub>
G	25.5	28	28	33	35	38	38	45	50	55
H	19.9	19.9	19.9	22.7	20.7	37.7	62.7	80.7	58.7	83.7
L	122	163	163	223	223	263	314	364	404	464
M	144	178	225	248	296	376	468	565	578	648
Set screws diameters	4xM8	6xM8	6xM8	6xM10	6xM12	6xM12	8xM12	12xM12	12xM12	12xM12
R	-	-	-	153 <sup>+0,1</sup> <sub>-0,1</sub>	191 <sup>+0,1</sup> <sub>-0,1</sub>	263 <sup>+0,1</sup> <sub>-0,1</sub>	350 <sup>+0,1</sup> <sub>-0,1</sub>	445 <sup>+0,1</sup> <sub>-0,1</sub>	410 <sup>+0,2</sup> <sub>-0,2</sub>	480 <sup>+0,2</sup> <sub>-0,2</sub>
S	-	-	-	35	35	35	35	35	57	57
T (H7)	-	-	-	276	330	415	505	605	620	690
U	-	-	-	21.5	21.5	21.5	20.5	20.5	36.5	36.5
V	-	-	-	3	3	3	3	3	4	4
W (t7)	-	-	-	120	165	240	335	430	390	460
Z	-	-	-	4xM12	4xM12	6xM12	6xM14	8xM14	8xM16	8xM18

BSAT Weight (kg) With Rough bore	12	22	39	56	85	157	290	411	518	721
BSAT J (kgm <sup>2</sup> ) Solid hub	0.0325	0.0825	0.2125	0.4	0.825	2.45	6.75	13.5	18.75	31.75
Maximum speed (Rpm)	Without balance	3600	2800	2000	2000	1700	1300	1000	800	700
	Dynamically balanced	5000	5000	4500	4200	3600	3000	2400	1800	1500

The contents of this bulletin are subject to change without notice.



## Type CPF with Brake Drum

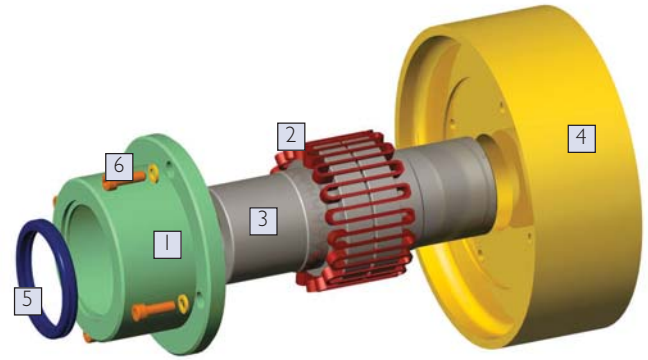
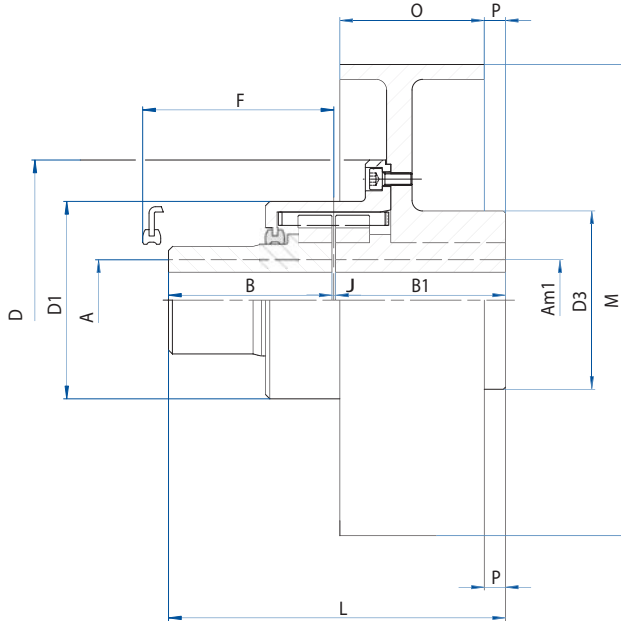

Item	Designation
1	Cover
2	Spring
3	Hub
4	Brake Drum
5	Seal
6	Screws

F: Clearance for grid spring assembly and removal

SIZE	0	1	2	5	9	16	28
<b>Nominal Torque (Nm)</b>	<b>950</b>	<b>1900</b>	<b>3800</b>	<b>8500</b>	<b>12500</b>	<b>24000</b>	<b>48000</b>
Am Keyway	55	80	110	105	130	180	230
AmI Keyway	50	70	110	100	115	150	220
Am Shrink Fit ♦	45	60	100	90	100	170	200
B	110	110	110	170	195	195	225
BI	110	110	110	170	195	210	250
D	170	205	250	286	340	425	515
D1	127	162	209	222	266	344	440
D3	120	160	225	220	185	255	330
F	120	120	120	187	187	187	190
J	2 <sup>+2</sup> <sub>-0,5</sub>	3 <sup>+1</sup> <sub>-1</sub>	3 <sup>+1</sup> <sub>-1</sub>	3 <sup>+1</sup> <sub>-1</sub>	3 <sup>+1</sup> <sub>-1</sub>	3 <sup>+1</sup> <sub>-1</sub>	4 <sup>+2</sup> <sub>-2</sub>
L	222	223	223	343	393	408	448
M	200	250	250	350	350	450	450
O	80	90	90	130	130	170	170
P	0	0	0	12	0	40	0
					25	15	40
					15	40	70
					15	40	70

Weight (kg) ⚡	25	33	42	61	76	87	116	169	198	242	272	322	421	462	588
J (kgm <sup>2</sup> ) with brake and solid hub	0.09	0.192	0.235	0.41	0.785	0.857	2.015	3.07	5.45	2.08	6.9	10	22.5	14.1	27.7
Maximum speed (Rpm)	Without balance		2400	1910	1910	1910	1360	1360	1060	1060	900	635	900	635	510

♦ Valid only for bore opposite to the brake.

⚡ Total weight with rough bore and inclusive of the brake drum.

The contents of this bulletin are subject to change without notice.

## Type S

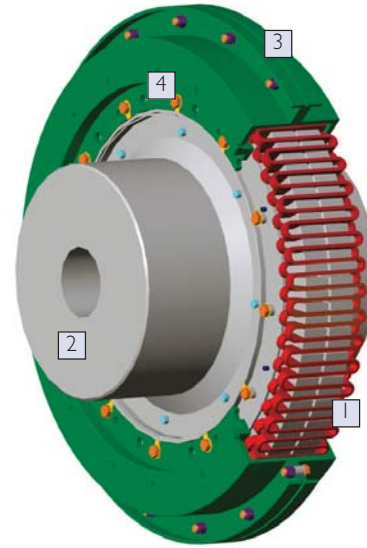
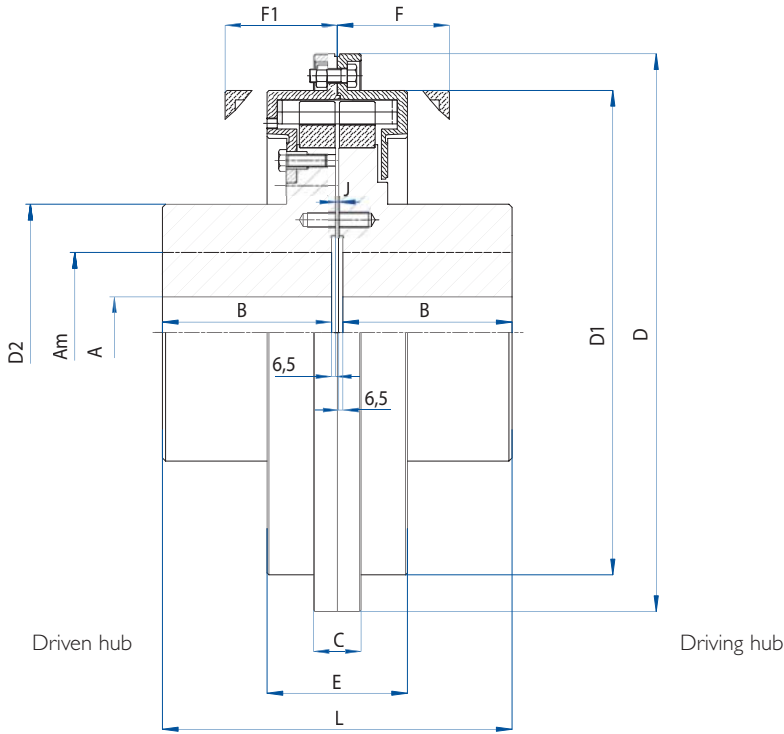

Item	Designation
1	Grid
2	Hub
3	Cover
4	Bolts & screws

F & F1: Clearance for grid spring assembly and removal





SIZE	150	220	300	380	480
<b>Nominal Torque (Nm)</b>	<b>270 000</b>	<b>400 000</b>	<b>540 000</b>	<b>700 000</b>	<b>800 000</b>
Am	270	300	340	370	390
A (Rough bore)	120	165	180	180	180
B	270	300	340	370	400
C	76	80	92	92	92
D1	773	910	1050	1195	1220
D2	410	450	550	600	620
E	224	220	224	224	265
F	210	210	210	210	250
F1	215	215	215	215	255
J	4 <sup>+2</sup> <sub>-2</sub>	5 <sup>+2</sup> <sub>-3</sub>	5 <sup>+2</sup> <sub>-3</sub>	5 <sup>+2</sup> <sub>-3</sub>	6 <sup>+2</sup> <sub>-3</sub>
L	557	618	698	758	819
2 Withdrawal holes diameter	360 M24	380 M24	450 M30	500 M30	-

Weight (kg) with Rough bore	990	1260	1860	2390	2830
Weight of grease (kg)	12	22	27	30	45
J (kgm <sup>2</sup> ) Solid hub	64.5	110.75	206.25	340	415.75
Max speed (Rpm)	Without balance	500	400	370	320
	Dynamically balanced	950	800	700	600

Am: Maximum permissible bore corresponding to the hub dimensions **which may be increased if it is required.**

The contents of this bulletin are subject to change without notice.

## Miscellaneous

SIZE		Z	000	00	0	1	2	5	9	16	28	43	70	95
	Weight (kg) Rough bore (mm)	0.69 -	1.35 -	2.7 -	3 -	7.2 -	13.8 -	17.8 30	27 30	56 60	113 75	150 85	182 95	263 105
	Weight (kg) Rough bore (mm)	- -	- -	- -	4.8 -	9.5 -	18.6 -	25.4 30	44 30	80 60	158 75	200 85	231 95	320 105
	COMPLETE GRID Weight (kg) segments Layers	0.075 1 1	0.105 1 1	0.140 1 1	0.480 2 1	0.620 2 1	0.840 2 1	2.6 4 2	3.7 4 2	5 4 2	6.5 6 2	8 8 2	22 8 2	25 8 2
	Weight (kg) Kit (cover, bolts, screws and seals)	0.38	0.85	1.07	1.32	1.6	2.5	4	5	7.8	12.2	19	23	28
	Weight (kg) Grease	0.06	0.09	0.11	0.17	0.3	0.35	1	1.3	1.6	1.8	2	4.5	8

## Special grease

- **Long life grease (\*) HPLD 9000**
- Extreme-pressure grease, unleaded high temperature NLGI 1 lithium soap-base grease. Made with a high viscosity oil and an extremely effective, heavy-duty additive package.
- Formulated to provide low bleed properties critical to modern couplings as well as high temperature stability.
- **Maintains its excellent performance characteristics in ambient temperatures up to 110°C.**

(\*) based on average period of 40 000 H. without greasing.



The contents of this bulletin are subject to change without notice.

# The driving force

## Flexible couplings



**Winflex DG**



**Flexacier 9000**



**Flexidisc**



**Flexident S**

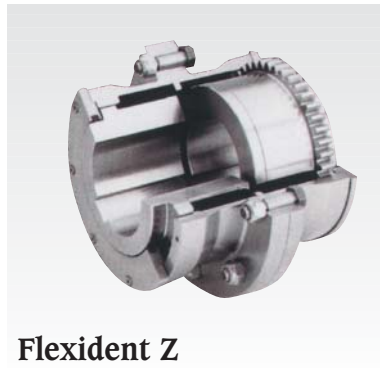

**Flexident Z**



**Tonoflex**



Unité CAMBRAI  
Certifiée ISO9001  
selon certificat n°352504



### SALES DEPARTEMENT

36, avenue de l'Europe – Immeuble l'Etendard  
BP 43 – 78142 VELIZY Cedex – FRANCE

**Tel.: +33 (0) 1 34 63 12 24** – Fax: +33 (0) 1 34 63 12 12  
E-mail : [accouplements@cmdgears.com](mailto:accouplements@cmdgears.com)

### HEAD OFFICE – FACTORY

539, avenue du Cateau – 59400 CAMBRAI - FRANCE

**Tel.: +33 (0) 3 27 73 53 11** – Fax: +33 (0) 3 27 78 36 99  
Web site : [www.cmd-transmissions.com](http://www.cmd-transmissions.com)