



Instructor's Manual  
for  
M-20.2 EEBD  
&  
M-20.2T Training Model

Manual / Part No: 340021  
Revision A, ECN 2368  
July 30, 2001

Ocenco Incorporated  
10225 82<sup>nd</sup> Avenue  
Pleasant Prairie, Wisconsin 53158-5801  
USA  
Phone: 262-947-9000  
Fax: 262-947-9020  
[www.ocenco-eebd.com](http://www.ocenco-eebd.com)

## TABLE OF CONTENTS

|  |    |
|--|----|
| 1. Introduction.....                                 | 3  |
| 2. M-20.2 EEBD .....                                 | 3  |
| 2.1. How the M-20.2 EEBD Works.....                  | 3  |
| 2.2. How to Don the M-20.2 EEBD.....                 | 6  |
| 2.3. How To Inspect the M-20.2 EEBD.....             | 6  |
| 2.4. How to Care for the M-20.2 EEBD .....           | 7  |
| 2.5. When to Don the M-20.2 EEBD.....                | 8  |
| 2.6. Specifications.....                             | 8  |
| 2.6.1. Duration .....                                | 8  |
| 2.6.2. Five Factors that Affect Duration .....       | 8  |
| 2.6.3. Dimensions .....                              | 9  |
| 2.6.4. Weight.....                                   | 9  |
| 2.6.5. Storage Temperature.....                      | 9  |
| 2.6.6. Service Life.....                             | 9  |
| 2.6.7. Conditions of Use .....                       | 9  |
| 2.6.8. Disposal and Return Instructions.....         | 9  |
| 3. M-20.2T Training Model.....                       | 10 |
| 3.1. Description of the M-20.2T Training Model ..... | 10 |
| 3.2. Theory of Operation.....                        | 12 |
| 3.3. Cleaning the M-20.2T Training Model.....        | 12 |
| 4. Training session Summary.....                     | 13 |
| 5. Related Information .....                         | 13 |
| 5.1. Effects of Oxygen Deficiency.....               | 14 |
| 5.2. Effects of Carbon Monoxide.....                 | 14 |

## 1. Introduction

This manual and the enclosed video are tools for conducting training classes in the proper use and inspection of the Ocenco M-20.2 EEBD. An M-20.2T training model is available for practicing the opening, and donning of the M-20.2 EEBD.

The Ocenco M-20.2 EEBD can be belt worn or stored in a wall bracket. The Ocenco M-20.2 EEBD is a self-contained, compressed oxygen, emergency escape breathing device (EEBD). The Ocenco M-20.2 EEBD instantly provides breathable air, independent of the surrounding atmosphere, to a person escaping from toxic gas or an oxygen deficient atmosphere.

The Ocenco M-20.2 EEBD meets the *International Convention For The Safety Of Life At Sea, SOLAS 1974, Chapter II-2* requirements for Emergency Escape Breathing Devices. The Ocenco M-20.2 EEBD also meets the *International Code For The Construction Of Ships Carrying Dangerous Chemicals In Bulk (IBC code)* and the *International Code For The Construction Of Ships Carrying Liquefied Gases In Bulk (IGC code)* requirements for a self-contained breathing apparatus with a normal duration of service of 15 minutes in maritime applications.

This Manual provides information on both the Ocenco M-20.2 EEBD and the Ocenco M-20.2T Training Model. The Instructor should cover the following topics:

- (1) How the M-20.2 EEBD works
- (2) How to don the M-20.2 EEBD
- (3) How to inspect the M-20.2 EEBD
- (4) How to care for the M-20.2 EEBD
- (5) When to don the M-20.2 EEBD
- (6) location of M-20.2 EEBDs (see ships fire control plan)

## 2. M-20.2 EEBD

### 2.1. How the M-20.2 EEBD Works

Oxygen automatically flows from the cylinder to the breathing bag when the device is pulled from its clear base.

During inhalation, and whenever the bag flattens, the oxygen regulator increases the oxygen flow into the breathing bag.

During inhalation and exhalation, the lithium hydroxide scrubber absorbs carbon dioxide.

During inhalation, oxygen passes from the breathing bag through the scrubber and into the mouthpiece.

During very low work rates, such as when the user is at rest waiting rescue, the oxygen regulator supplies more oxygen than the user can consume. When this occurs, the excess gas automatically vents through the relief valve.

The M-20.2 EEBD operates automatically. This includes the starting of the oxygen flow, the increased oxygen flow rate during high work periods, and the venting of excess gas through the relief valve.

**The components of the M-20.2 EEBD are: (see illustration on next page)**

- (1) **Nose Clip** - the yellow nose clip is permanently attached to the mouthpiece.
- (2) **Mouthpiece** - the yellow mouthpiece is placed in the mouth such that the flange seals between the lips and gums. The bits should be between the upper and lower teeth. Gently bite on the bits.
- (3) **Neck Strap** - the yellow neck strap is placed over the head for support and can be adjusted for fit.
- (4) **Oxygen Cylinder** - the stainless steel cylinder holds 100% medical grade oxygen.
- (5) **Oxygen Regulator** - starts the flow of oxygen and increases the oxygen flow during high work rates.
- (6) **Activation Cable** - the stainless steel activation cable is attached to the oxygen regulator and permanently attached to the inside of the base.
- (7) **Gauge** - indicates the amount of oxygen in the cylinder. The green zone indicates the M-20.2 EEBD is ready for use. The red zone indicates the cylinder is low on oxygen and should be removed from service. The gauge is visible through the clear case and the orange secondary container.
- (8) **Scrubber** - a chamber containing lithium hydroxide that removes carbon dioxide from the exhaled air.
- (9) **Breathing Bag** - air reservoir that receives oxygen from the regulator and exhaled air from the user.
- (10) **Relief Valve** - a one way valve that automatically allows excess air in the breathing bag to vent.
- (11) **Yellow Lever** - the yellow lever is lifted upwards to open the M-20.2 EEBD.
- (12) **Cover** - may have optional overcase pads, a user replaceable item that provides increased abrasion and impact resistance.
- (13) **Base** - if belt worn, the base stays on the belt after the M-20.2 EEBD has been removed from the case. The base has an overcase pad that provides increased abrasion and impact resistance.
- (14) **S-Hook** - the metal hook that receives the cover latch on the belt side.
- (15) **Face Shield** - in the event the user requires head protection from smoke or chemical vapor, the face shield may be pulled up over the head and secured around the neck by pulling outward on the draw strings. This should be done only after inserting the mouthpiece and applying the nose clips. The Face Shield is not part of the breathing circuit and is not required for respiratory protection.
- (16) **Bag Shield** - a cover over the breathing bag providing additional protection to the breathing bag.
- (17) **Tamper Indicating Ball** - the presence of a stainless steel ball bearing located in the center of the yellow lever assures that the unit has not been opened.
- (18) **Band Label** - user completed label indicating date of belt worn service.
- (19) **Information Label** - contains the following information:
  - MFG DATE XX/XX, the date of manufacture as month/year
  - LIFE DATE XX/XX, the end of service life date as month/year
  - SERIAL NO X123456, the traceable serial number of the M-20.2 EEBD
  - FINAL INSP, XX, quality control final inspection
  - MOUTHPIECE, X-12, the traceable lot number of the mouthpiece
  - LiOH LOT, 123-X12, the traceable lot number of the LiOH
  - SCRUBBER, X12345, the traceable lot number of the scrubber
  - BAG LOT, XX1234, the traceable lot number of the breathing bag
  - CYLINDER, XXX, the traceable lot number of the cylinder
  - LEAK TEST, XX, quality control final leak test

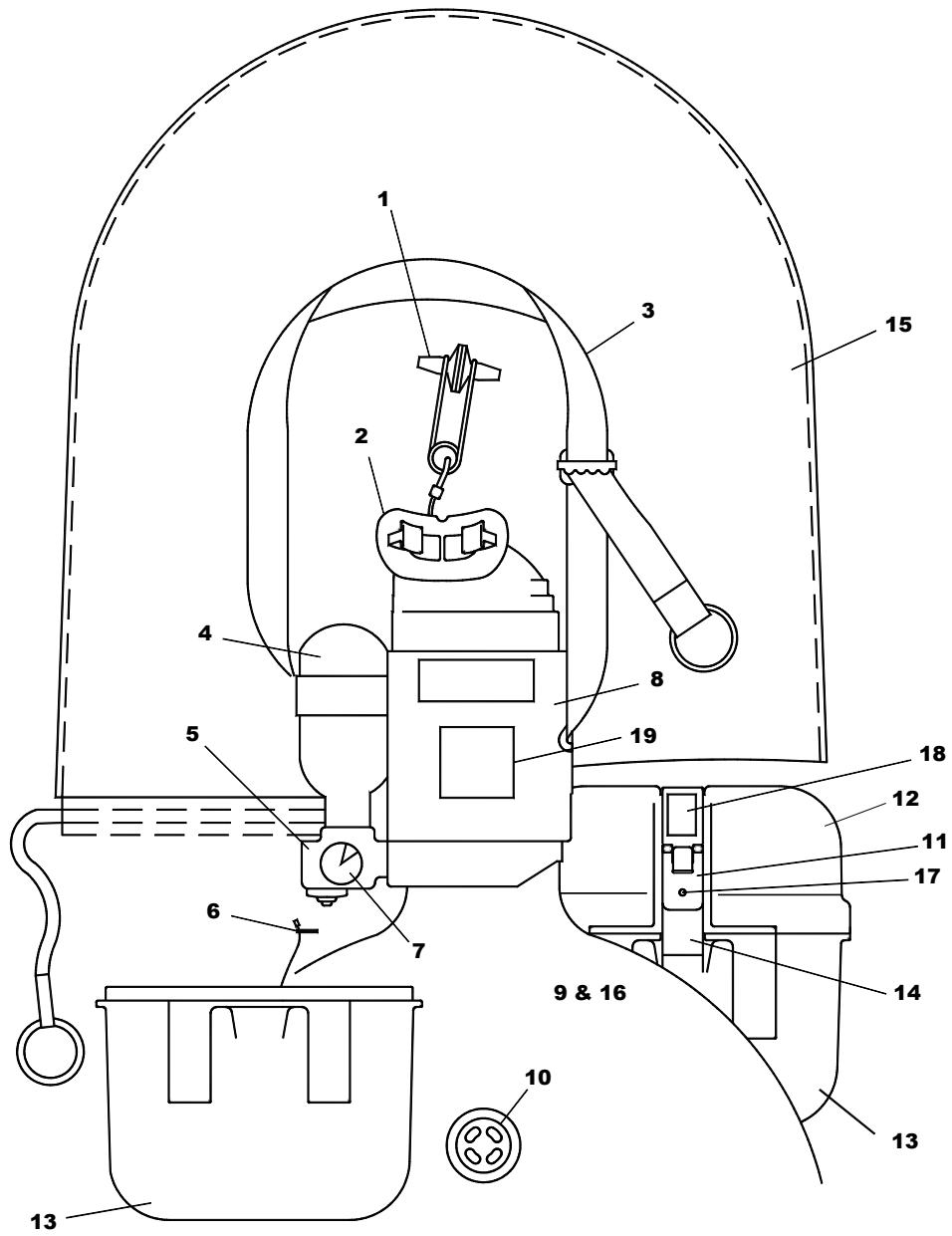

## 2.2. How to Don the M-20.2 EEBD

The following are the donning steps for the belt worn configuration of the M-20.2 EEBD. If the M-20.2 EEBD is wall mounted, first remove the case from the wall. These six steps must be practiced numerous times until they become second nature.

**1** REMOVE EEBD FROM ORANGE CASE

**2** LIFT YELLOW LEVER AND DISCARD COVER



**3** REMOVE UNIT BY PULLING YELLOW NECK STRAP UPWARDS



**4** INSERT YELLOW MOUTHPIECE



**5** FIT YELLOW NOSE CLIP



**6** INHALE THROUGH MOUTH AND ESCAPE

*ADJUST YELLOW NECK STRAP AND DON FACE SHIELD IF NEEDED*

To fit the neck strap, simply place the neck strap over the head and, if necessary, pull upward on the o-ring to shorten the neck strap.

To fit the face shield, open the face shield by putting a hand inside the face shield and then pull the face shield over the head and pull outward on the o-rings to tighten the face shield around the neck.

If moisture on the inside of the face shield distorts your vision, simply press or rub the face shield against the face with your hand.

## 2.3. How To Inspect the M-20.2 EEBD

The only inspections required for the M-20.2 EEBD are visual inspections. Remove the M-20.2 EEBD from the orange secondary container but do **not** open the clear case to inspect the M-20.2 EEBD.

### (1) Read the pressure gauge.

- If belt worn, read the pressure gauge at the beginning of each work shift.
- If stored, the pressure gauge should be read at least every two years.

The tip of the white needle on the gauge is normally in the green zone. If the needle is in the red zone or on the white zero pressure mark, remove the M-20.2 EEBD from service. If the view of the gauge is obstructed, remove the M-20.2 EEBD from service.

If the surrounding air temperature is above 38° C (100°F), and the needle is in the red zone, above the green zone, allow the M-20.2 EEBD to cool down to 18° - 24° C (64° - 75°F) for 24 hours. If the needle returns to the green zone, keep the M-20.2 EEBD in service. If the needle does not return to the green zone, remove the M-20.2 EEBD from service.

**(2) Visually inspect the M-20.2 EEBD for indications of abuse.**

Indications of abuse are listed below. If any of these signs are present, remove the M-20.2 EEBD from service:

- a) Case is cracked, burned, deformed or excessively worn
- b) Signs of heat distortion
- c) Damaged latch or cover band
- d) Dirt, debris, or moisture visible through the case
- e) Belt loops broken
- f) Missing tamper indicating ball

If the M-20.2 EEBD fails any of the above inspections, or if at any time during its life the pressure gauge is out of the green zone, it should be removed from service.

- (3) Check the LIFE DATE on the Information Label.** If the M-20.2 EEBD has exceeded the LIFE DATE, remove the M-20.2 EEBD from service.
- (4) Check the BELT WORN date on the Band Label.** If the belt worn M-20.2 EEBD has exceeded the five year belt worn period, either put it in an orange Secondary Container and place in a stored position or, return for factory service.

## **2.4. How to Care for the M-20.2 EEBD**

The M-20.2 EEBD is designed to be used in a marine environment. However, it is not indestructible.

Abusing your M-20.2 EEBD is risking your life in the event of an emergency. Abusing someone else's M-20.2 EEBD should be considered a criminal offense.

Your life may depend on the care you give your M-20.2 EEBD. Avoid the most common abuses.

- (1) If the M-20.2 EEBD is accidentally opened, do not close it
- (2) Do not drop the M-20.2 EEBD, particularly when removing it from the belt
- (3) Do not clean the M-20.2 EEBD with any cleaning solvents, only use a soft brush
- (4) Do not immerse the M-20.2 EEBD in water
- (5) Do not sit on the M-20.2 EEBD
- (6) Do not drag the M-20.2 EEBD on the deck
- (7) Do not place the M-20.2 EEBD near a heat source greater than 60°C (140°F)
- (8) Do not put tape or stickers on the M-20.2 EEBD that would impede its opening or the reading of the gauge, Information Label or Band Label

## 2.5. When to Don the M-20.2 EEBD

The M-20.2 EEBD should be donned immediately at the first indication of a fire or explosion, even if smoke is not visible. Carbon monoxide is odorless and colorless. You could breathe a fatal amount of carbon monoxide before smoke is present. If you suspect an oxygen deficient atmosphere, put on the M-20.2 EEBD. **Don't Wait!** Some of the possible indications of an emergency are:

- (1) Sight of smoke
- (2) Smell of smoke
- (3) Sight of fire
- (4) Fire or toxic gas alarm
- (5) Sudden increase of air temperature
- (6) Sound of an explosion
- (7) Vibrations of an explosion
- (8) Interruption of air flow
- (9) Someone around you has difficulty breathing or passes out
- (10) Accidental release of hazardous material

In the event of an emergency, always don your M-20.2 EEBD before attempting to escape or help others.

## 2.6. Specifications

### 2.6.1. Duration

**15 minutes, normal duration of service in maritime application**

31 minutes, at rest, as determined by EN 400, Section 6.2.4

32 minutes, at rest, as determined by US 42 CFR 84 mantest number 5

10 minutes, US 42 CFR 84, Dept. of Health and Human Services, NIOSH

10 minutes, European Standard EN 400, EC mark CE0194/EN 400

### 2.6.2. Five Factors that Affect Duration

- (1) The amount of work required to escape affects the duration. Steep inclines or ladders, and irregular floors increase the work required to escape. Less work results in greater duration.
- (2) The physical condition or fitness of the user affects the duration. An elevated heart rate, age and high percent of body fat decrease the fitness of the subject. The more fit the user, the greater the duration.
- (3) Regardless of the fitness of the user, the amount of oxygen required is proportional to the user's weight. The less the user weighs, the greater the duration.
- (4) The user's respiration or breathing rate affects the duration. Excitement and fear can increase the breathing rate. The lower the breathing rate, the greater the duration.
- (5) The degree of training and familiarity can affect the duration. The more training and experience the subject has with an EEBD, the more his breathing will be calm and controlled. If a subject is familiar with the escape-way, it may improve the mechanics of his escape. The greater the training and familiarity, the greater the duration.



### **2.6.3. Dimensions**

8.1 x 17.3 x 15.5 cm (3.2 x 6.8 x 6.1 in)

### **2.6.4. Weight**

0.94 kilograms, breathing apparatus only (2 lb.)

1.4 kilograms, breathing apparatus in case (3 lb.)

### **2.6.5. Storage Temperature**

Minimum: -15 degrees C (5 degrees F)

Maximum: 60 degrees C (140 degrees F)

### **2.6.6. Service Life**

The M-20.2 EEBD may remain in service for fifteen years from the date of manufacture, provided the conditions of use are observed. The M-20.2 EEBD must be either stored or belt worn, according to the conditions of use, throughout its service life.

- If the M-20.2 EEBD is belt worn, after five years it must be placed in a stored position or returned for factory service.
- If the M-20.2 EEBD is stored it may remain in service for fifteen years without factory service. The stored M-20.2 EEBD should be removed from service when it exceeds the LIFE DATE.

### **2.6.7. Conditions of Use**

- (1) the visual inspections described in this manual must be performed,
- (2) proper care described in this manual must be performed,
- (3) when stored, the M-20.2 EEBD must be contained in an Ocenco, Incorporated Secondary Container and then placed in a rigid bracket securely fastened to a wall or other substantial structure and,
- (4) if worn, the M-20.2 EEBD must be belt worn on the person for no more than one shift per day.

### **2.6.8. Disposal and Return Instructions**

The M-20.2 EEBD must be shipped in accordance with applicable regulations.

- Each M-20.2 EEBD contains 0.14 Kg (0.31 lbs.) of hazardous material.
- The hazardous material description and proper shipping name are *Life-Saving Appliance, Not Self-Inflating*
- Hazard Class or Division: 9
- Identification number: UN3072
- Labels required: Class 9

### 3. M-20.2T Training Model

#### 3.1. Description of the M-20.2T Training Model

The M-20.2T Training Model is designed to look like, don like and have the breathing resistance similar to the M-20.2 EEBD. See the next page for a diagram of the following components:

- (1) **Cover** - The M-20.2T Cover is similar in appearance to the M-20.2 EEBD Cover.
- (2) **Base** - The M-20.2T Base is similar in appearance to the M-20.2 EEBD Base. A “*Caution For Training Use Only*” label is on the front of the M-20.2T Base.
- (3) **Latch Assembly** - similar to the M-20.2 EEBD Latch Assembly
- (4) **Noseclip** - similar to the M-20.2 EEBD Noseclip
- (5) **Mouthpiece** - simulates breathing resistance of the M-20.2 EEBD with holes in the body of the Mouthpiece. It does not allow the exhaled air to enter the Scrubber or the Breathing Bag. Therefore, only the Mouthpiece needs to be cleaned after use.
- (6) **Neck Strap** - similar to the M-20.2 EEBD Neck Strap.
- (7) **Neck Strap Ring** - similar to the M-20.2 EEBD Neck Strap Ring.
- (8) **Cylinder** - a non-functional model.
- (9) **Oxygen Regulator** - a non-functional model.
- (10) **Activation Cable** - attached to the Oxygen Regulator with a steel snap and permanently attached to the inside of the Base. Pulling upwards on the Neck Strap unsnaps the Activation Cable from the Oxygen Regulator. This gives the student the sensation of the force of activating the flow of oxygen.
- (11) **Gauge** - the Gauge is simulated with a label on the inside of the Case. This allows the student to read the Gauge during training.
- (12) **Spring Clip** - releases the Mouthpiece for cleaning.
- (13) **Scrubber** - a non-functional model.
- (14) **Breathing Bag** - a non-functional model.
- (15) **S-Hook** – the metal hook that receives the cover latch on the belt side.
- (16) **Information Label** - simulates inspection of the LIFE DATE.

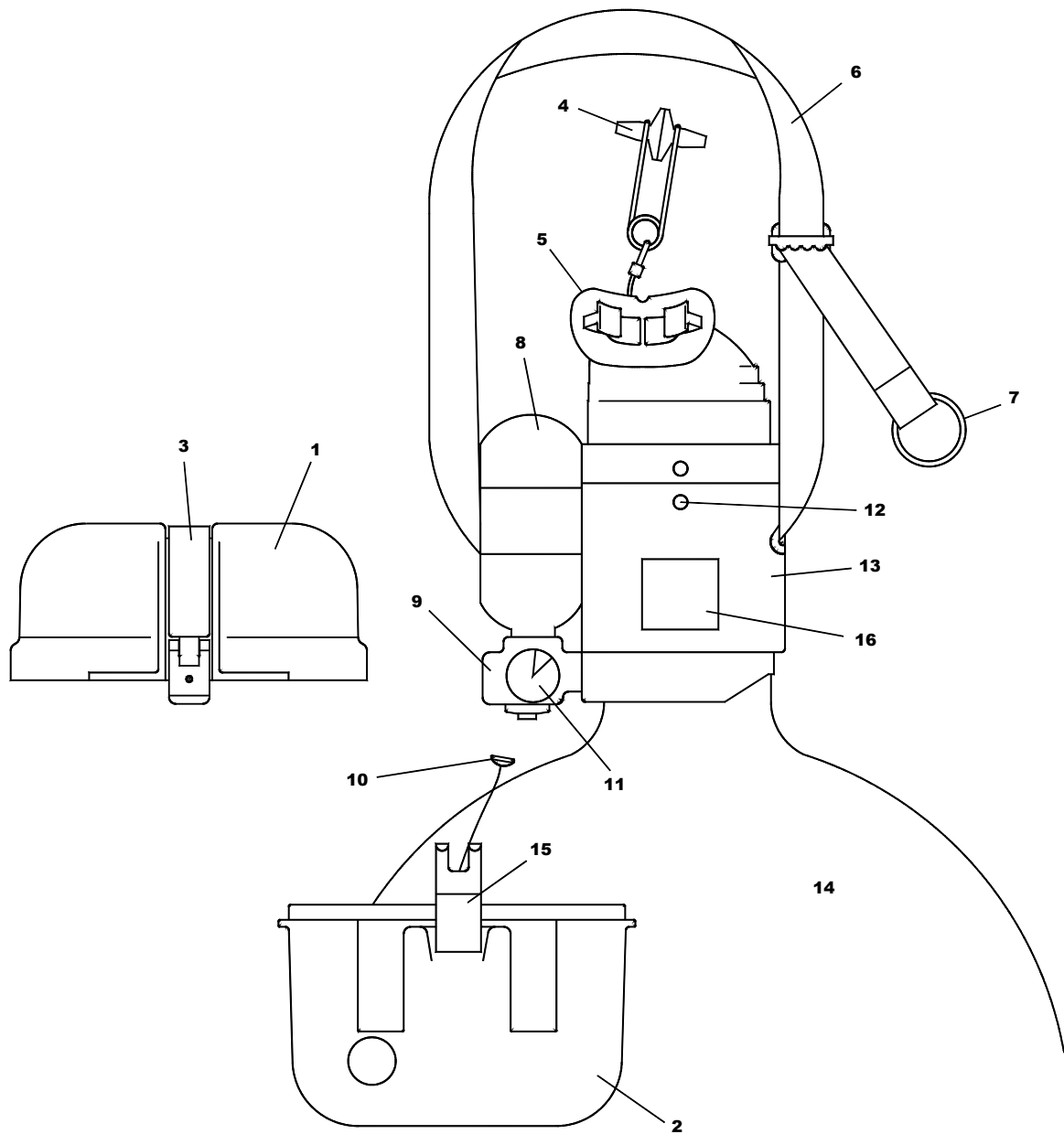

### **3.2. Theory of Operation**

Opening and donning an M-20.2 EEBD is a motor skill. The most effective method of teaching a motor skill is to have the student repetitively perform the motor skill.

It is essential that the student have “hands on” experience with the M-20.2T. The more often a student has the M-20.2T in his hands and the more often he dons the M-20.2T, the better his recall will be.

The following describes the simple theory of operation of the M-20.2T.

- (1) The M-20.2T is worn on the belt to demonstrate the proper orientation on the belt or placed in the blue Secondary Container to simulate the stored position.
- (2) The Latch Assembly is identical to the M-20.2 EEBD, so that the opening of the M-20.2T is practiced “hands on”.
- (3) As the Neck Strap is pulled from the Base, the Activation Cable Snap disconnects from the Oxygen Regulator, simulating the oxygen activation on the M-20.2 EEBD.
- (4) During inhalation, air is supplied to the student from the atmosphere through the holes in the Mouthpiece.
- (5) During exhalation, air is exhaled into the Mouthpiece, passing through the holes in the Mouthpiece to the atmosphere. During inhalation and exhalation, the breathing resistance through the Mouthpiece holes simulates the breathing resistance of the M-20.2 EEBD.

### **3.3. Cleaning the M-20.2T Training Model**

Please refer to the training video for a demonstration of cleaning and re-packing the M-20.2T Training Model.

The steps to clean and re-pack the M-20.2T are:

- (1) Return the Neck Strap length to the fully extended position.
- (2) Remove the Mouthpiece from the Scrubber by pushing in the Spring Clip through the hole in the Scrubber.
- (3) Pull upwards on the Mouthpiece, removing it from the Scrubber.
- (4) Wash Mouthpiece thoroughly in disinfectant. Use a 10% chlorine bleach solution or other disinfectant solution approved for shipboard use.
- (5) Rinse and dry.
- (6) Snap the Mouthpiece onto the Spring Clips.
- (7) Fold the Breathing Bag into a rectangle no larger than the bottom of the Scrubber.
- (8) Snap the Activation Cable onto the Oxygen Regulator.
- (9) Carefully set the M-20.2T into the Base while holding the Breathing Bag (folded) against the bottom of the Scrubber. It may be helpful to use a strap to help hold the Breathing Bag in place. Remove the strap after the M-20.2T is in the Base.
- (10) Fold the Mouthpiece and Noseclip as flat as possible, hold in place.
- (11) Fold the Neck Strap on top of the Mouthpiece and Cylinder.
- (12) Place the Cover on the Base.
- (13) Hook the S-Hook on the Belt Loop side of the Base with the two hooks curling away from the case.
- (14) Hook the Latch Assembly on the front side of the Base.
- (15) Bring the Latch Assembly over the Cover, engage the two yellow forks on the lever in the curled tabs of the S-Hook and push down on the yellow lever.

## 4. Training session Summary

The following topics should be covered during the training session:

- (1) **Why do you need an M-20.2 EEBD?** To protect the user from toxic or oxygen deficient atmosphere in the event of a fire or explosion; chemical or gas spill or leakage.
- (2) **When should a person don the M-20.2 EEBD?** The EEBD should be put on at the first indication of fire, explosion or suspected oxygen deficiency, when you feel faint or a person near you faints. Use when instructed to do so by your supervisor or if a toxic gas or smoke alarm is heard.
- (3) **How long will the M-20.2 EEBD protect you?** The M-20.2 EEBD will normally protect the user 15 to 20 minutes during escape and up to 32 minutes when at rest.
- (4) **Why is the face shield provided?** The face shield or hood is provided to protect the eyes and face from irritating smoke or vapors.
- (5) **When may the M-20.2 EEBD be removed during an escape?** Do not take off the EEBD until you have reached a safe atmosphere or when the EEBD is out of oxygen.
- (6) **What are the visual inspection steps?** See pages 6 & 7
- (7) **When should the M-20.2 EEBD be removed from service?** Remove the EEBD from service when the unit fails any of the visual inspection steps or the unit exceeds the service life (see page 9 for service life description).
- (8) **When must the M-20.2 EEBD be visually inspected?** If the EEBD is belt worn, it must be inspected daily, at the beginning of the work shift. When the EEBD is stored in it's secondary container, it must be inspected at least every two (2) years.
- (9) **What are the six (6) steps for properly donning the M-20.2 EEBD?** See page 6.

## 5. Related Information

- (1) Earth's atmosphere composition, nominal at sea level:

| <u>Gas</u>     | <u>Percent by Volume</u> |
|----------------|--------------------------|
| Nitrogen       | 78.09                    |
| Oxygen         | 20.95                    |
| Argon          | 0.93                     |
| Carbon dioxide | 0.04                     |

- (2) EEBD - an emergency escape breathing device that is self-contained. An EEBD is used for respiratory protection and is capable of supporting life during escape from an oxygen deficient or contaminated environment.
- (3) Oxygen Deficiency - when the percentage of oxygen in the atmosphere is not sufficient to sustain life.
- (4) Scrubber - a component of an escape breathing device that removes carbon dioxide
- (5) Carbon Monoxide - a colorless, odorless, very toxic gas formed as the product of incomplete combustion of materials containing carbon. This gas is formed during fires and after explosions.

## **5.1. Effects of Oxygen Deficiency**

Oxygen is odorless, colorless and tasteless, so it's presence or absence is impossible to detect with the senses. However, when the air you breathe is deficient in oxygen, some of the physiological effects you may experience can give you clues that you are in an oxygen deficient atmosphere.

People breathing air that has as little as 13% to 17% oxygen usually become dizzy, notice buzzing in their ears, can have a rapid heart rate, and often suffer headaches. They may faint or become unconscious when the air contains 9% oxygen. In air with less than 6% oxygen, movements become convulsive, and breathing comes in intermittent gasps that finally stop. Within only a few minutes after breathing stops, the heart also stops.

While these are the effects of oxygen deficiency that generally occur at the corresponding oxygen levels, you will not necessarily experience the whole list of systems if you are in an oxygen deficient atmosphere.

If you should encounter an atmosphere that contains about 10% oxygen, you may not have time to experience any of the above symptoms before collapsing.

Remember that in an oxygen deficient atmosphere, time is important, oxygen is necessary to support life.

## **5.2. Effects of Carbon Monoxide**

Carbon Monoxide is a product of incomplete combustion of solid, liquid, or gaseous material that contains carbon.

It is poisonous in very low concentrations because it displaces oxygen in the bloodstream.

The severity of these effects depends on the concentration.

- 0.04 to 0.05 percent carbon monoxide can be inhaled for 1 hour without appreciable effect.
- 0.06" to 0.07 percent, just noticeable effects after 1 hour exposure.
- 0.10 to 0.12 percent, unpleasant but probably not dangerous after 1 hour exposure.
- 0.15 to 0.20 percent is dangerous for exposure of 1 hour. Death could occur in less than 1 hour for an exposure of 0.40% carbon monoxide.

Some of the symptoms of carbon monoxide poisoning are headaches, dizziness, and nausea. The symptoms of carbon monoxide poisoning decrease in number as concentration of carbon monoxide in the air increases. In other words, the higher the concentrations of carbon monoxide in the air, the fewer symptoms a person will experience. Someone suddenly exposed to a high concentration may collapse before experiencing any warning symptoms. For example, a person breathing 1% carbon monoxide concentration may collapse in only 1 minute. Therefore, when an explosion or fire occurs, high concentrations of carbon monoxide may exist. Time is critical.