



**Bonfiglioli**  
Tecnoingranaggi

---

## KR series

Precision right-angle gearboxes



**Bonfiglioli**

power, control and green solutions



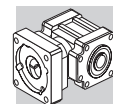

## SUMMARY



<b>1 General information</b> .....	3
1.1 Symbols, units and definitions .....	3
1.2 Selecting the gear unit .....	4
<b>2 Features of KR series</b> .....	6
2.1 Versions .....	7
2.2 Mounting positions .....	7
2.3 Coordinated shaft rotation .....	7
<b>3 Ordering code</b> .....	8
<b>4 Technical specifications</b> .....	9
<b>5 Mass moment of inertia</b> .....	10
5.1 KR 010...KR 040 with standard ball bearings .....	10
5.2 KR 020...KR 040 with taper roller bearings (HDB option) .....	11
<b>6 Dimensions</b> .....	12
KR 010 .....	12
KR 020 .....	14
KR 030 .....	16
KR 040 .....	18
6.1 Gearbox without motor adapter - FM .....	20
6.2 Machine shaft .....	21

### Revisions

Refer to page 22 for the catalogue revision index.

Visit [www.bonfiglioli.com](http://www.bonfiglioli.com) to search for catalogues with up-to-date revisions.

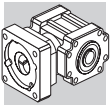

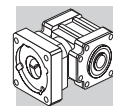

## 1 GENERAL INFORMATION

### 1.1 SYMBOLS, UNITS AND DEFINITIONS

#### Values depending on the **APPLICATION**

term	u.m.	definition
<b>A<sub>2</sub></b>	[N]	Thrust force on output shaft
<b>A<sub>2</sub> EQU</b>	[N]	Equivalent thrust force applying on output shaft
<b>A<sub>2</sub> MAX</b>	[N]	Maximum thrust force applying on output shaft
<b>R<sub>2</sub></b>	[N]	Radial force on output shaft
<b>R<sub>2</sub> EQU</b>	[N]	Equivalent radial force applying on output shaft
<b>R<sub>2</sub> MAX</b>	[N]	Maximum radial force applying on output shaft
<b>ED</b>	[min]	Loading time
<b>ED%</b>	[%]	Loading time %
<b>L<sub>10h</sub> TARGET</b>	[h]	Output shaft bearings' desired basic rating life
<b>M<sub>1</sub> PEAK</b>	[Nm]	Maximum input torque (usually motor)
<b>M<sub>2(1) ... M<sub>2(n)</sub></sub></b>	[Nm]	Output torque at each of the time periods t <sub>1</sub> ... t <sub>n</sub>
<b>M<sub>2</sub> EQU</b>	[Nm]	Equivalent output torque
<b>M<sub>2</sub> MAX</b>	[Nm]	Maximum output torque in case of emergency
<b>M<sub>T2</sub> EQU</b>	[Nm]	Equivalent tilting moment applying on output shaft
<b>M<sub>T2</sub> MAX</b>	[Nm]	Maximum tilting moment applying on output shaft
<b>n<sub>2</sub></b>	[min <sup>-1</sup> ]	Output speed
<b>n<sub>2(1) ... n<sub>2(n)</sub></sub></b>	[min <sup>-1</sup> ]	Output speed based on the time periods t <sub>1</sub> ... t <sub>n</sub>
<b>n<sub>2</sub> EQU</b>	[min <sup>-1</sup> ]	Equivalent output speed
<b>n<sub>2</sub> MAX</b>	[min <sup>-1</sup> ]	Maximum output speed
<b>T</b>	[C°]	Ambient temperature
<b>t<sub>1</sub> ... t<sub>n</sub></b>	[s]	Time periods of motion
<b>t<sub>Σ</sub></b>	[s]	Cycle duration including pause
<b>Z</b>	[1/h]	Cycle number per hour

#### Values depending on the **GEAR DRIVE SELECTION**

term	u.m.	definition
<b>A<sub>2 3 max</sub></b>	[N]	Admissible thrust force on output shaft
<b>A<sub>2' max</sub></b>	[N]	Thrust force acting simultaneously with the rated radial force
<b>R<sub>1 max</sub></b>	[N]	Admissible radial force at midpoint of input shaft
<b>R<sub>2 3 max</sub></b>	[N]	Admissible radial force at midpoint of output shaft
<b>C<sub>B</sub></b>	[Nm]	Constant for bearing's lifetime calculation
<b>C<sub>t</sub></b>	$\left[ \frac{\text{Nm}}{\text{arcmin}} \right]$	Torsional stiffness
<b>f<sub>n</sub></b>	—	Speed factor
<b>f<sub>z</sub></b>	—	Cycle factor
<b>f<sub>T</sub></b>	—	Temperature adjusting factor
<b>i</b>	—	Gearbox ratio
<b>J<sub>G</sub></b>	[kgcm <sup>2</sup> ]	Mass moment of inertia of the gearhead
<b>K<sub>n</sub></b>	—	Speed constant
<b>L<sub>10h</sub></b>	[h]	Bearings' basic rating life
<b>L<sub>Z</sub></b>	[mm]	Factor for bearing's lifetime calculation
<b>M<sub>a 2</sub></b>	[Nm]	Maximum acceleration output torque
<b>M<sub>n 2</sub></b>	[Nm]	Rated output torque
<b>M<sub>p 2</sub></b>	[Nm]	Emergency stop output torque
<b>M<sub>T2 max</sub></b>	[Nm]	Maximum tilting moment applying on output shaft
<b>n<sub>1 max</sub></b>	[min <sup>-1</sup> ]	Maximum momentary input speed. The speed the unit can be driven at occasionally and in non-repetitive conditions For cycle duty type S5, it cannot be applied continuously for more than 30 seconds
<b>p</b>	—	Bearing lifetime exponent
<b>η</b>	[%]	Gear efficiency
<b>φ<sub>R</sub></b>	[arcmin]	Reduced backlash is calculated in static conditions and with the application of a torque equal to 2% of the gear unit rated torque
<b>φ<sub>S</sub></b>	[arcmin]	Standard backlash is calculated in static conditions and with the application of a torque equal to 2% of the gear unit rated torque

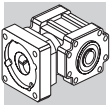

## 1.2 SELECTING THE GEAR UNIT

(a)	Ratio	$i$	—	$i = \frac{n_1}{n_2}$														
(b)	Equivalent output torque	$M_{2\text{ EQU}}$	[Nm]	$M_{2\text{ EQU}} = \sqrt[3]{\frac{n_{2(1)} \cdot t_1 \cdot  M_{2(1)} ^3 + \dots + n_{2(n)} \cdot t_n \cdot  M_{2(n)} ^3}{n_{2(1)} \cdot t_1 + \dots + n_{2(n)} \cdot t_n}}$														
(c)	Equivalent output speed	$n_{2\text{ EQU}}$	[min <sup>-1</sup> ]	$n_{2\text{ EQU}} = \frac{n_{2(1)} \cdot t_1 + n_{2(2)} \cdot t_2 + \dots + n_{2(n)} \cdot t_n}{t_\Sigma}$														
(d)	Speed factor	$f_n$	—	<p>If <math>\frac{K_n}{n_{2\text{ EQU}} \cdot i} \geq 1 \Rightarrow f_n = 1</math></p> <p>If <math>\frac{K_n}{n_{2\text{ EQU}} \cdot i} &lt; 1 \Rightarrow f_n = \text{Obtain from diagram}</math></p>														
(e)	Loading time %	ED%	[%]	$ED\% = \frac{t_1 + t_2 + \dots + t_n}{t_\Sigma} \cdot 100$														
	Loading time	ED	[min]	$ED = t_1 + t_2 + \dots + t_n$														
(f)	Cycle number per hour	Z	[1/h]	$Z = \frac{3600}{t_\Sigma}$														
(g)	Cycle factor	$f_z$	—	<table border="1"> <thead> <tr> <th>Z</th> <th><math>f_z</math></th> </tr> </thead> <tbody> <tr> <td><math>Z \leq 1000</math></td> <td>1.00</td> </tr> <tr> <td><math>1000 &lt; Z \leq 1500</math></td> <td>1.25</td> </tr> <tr> <td><math>1500 &lt; Z \leq 2500</math></td> <td>1.50</td> </tr> <tr> <td><math>2500 &lt; Z \leq 4000</math></td> <td>1.75</td> </tr> <tr> <td><math>4000 &lt; Z \leq 6000</math></td> <td>2.00</td> </tr> <tr> <td><math>Z &gt; 6000</math></td> <td>contact us</td> </tr> </tbody> </table>	Z	$f_z$	$Z \leq 1000$	1.00	$1000 < Z \leq 1500$	1.25	$1500 < Z \leq 2500$	1.50	$2500 < Z \leq 4000$	1.75	$4000 < Z \leq 6000$	2.00	$Z > 6000$	contact us
Z	$f_z$																	
$Z \leq 1000$	1.00																	
$1000 < Z \leq 1500$	1.25																	
$1500 < Z \leq 2500$	1.50																	
$2500 < Z \leq 4000$	1.75																	
$4000 < Z \leq 6000$	2.00																	
$Z > 6000$	contact us																	
(h)	Temperature adjusting factor	$f_T$	—	<p>If <math>T \leq 30^\circ\text{C} \Rightarrow f_T = 1</math></p> <p>If <math>T &gt; 30^\circ\text{C} \Rightarrow f_T = 1 + \frac{T - 30}{100}</math></p>														
(i)	Maximum input torque	$M_{1\text{ PEAK}}$	[Nm]	<p>a) maximum possible application torque</p> <p>b) limited motor torque by inverter</p> <p>c) maximum motor torque</p>														

$K_n$ - speed constant				
$i$	KR 010	KR 020	KR 030	KR 040
1	1200	1200	1000	800
2	2400	2400	2000	1600
5	3000	3000	2800	2500

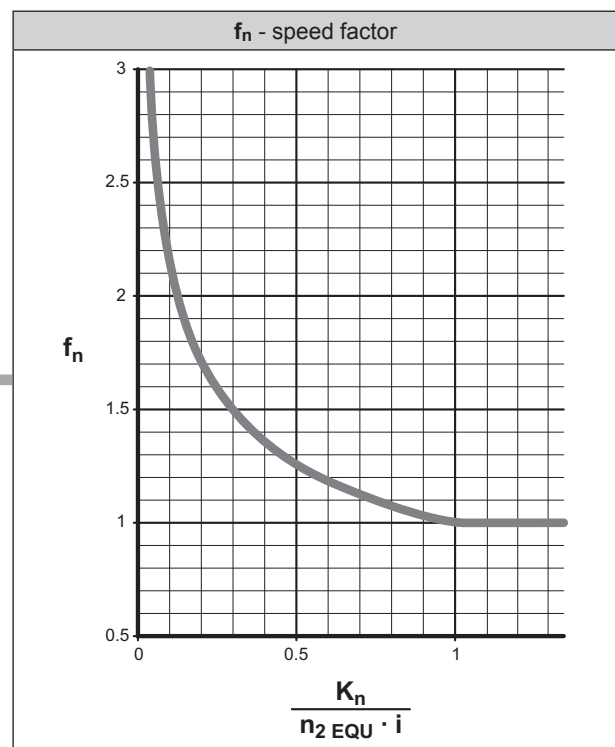

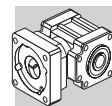

### Load diagram

—  $M_2$ : Output torque

### Speed diagram

—  $n_2$ : Output speed

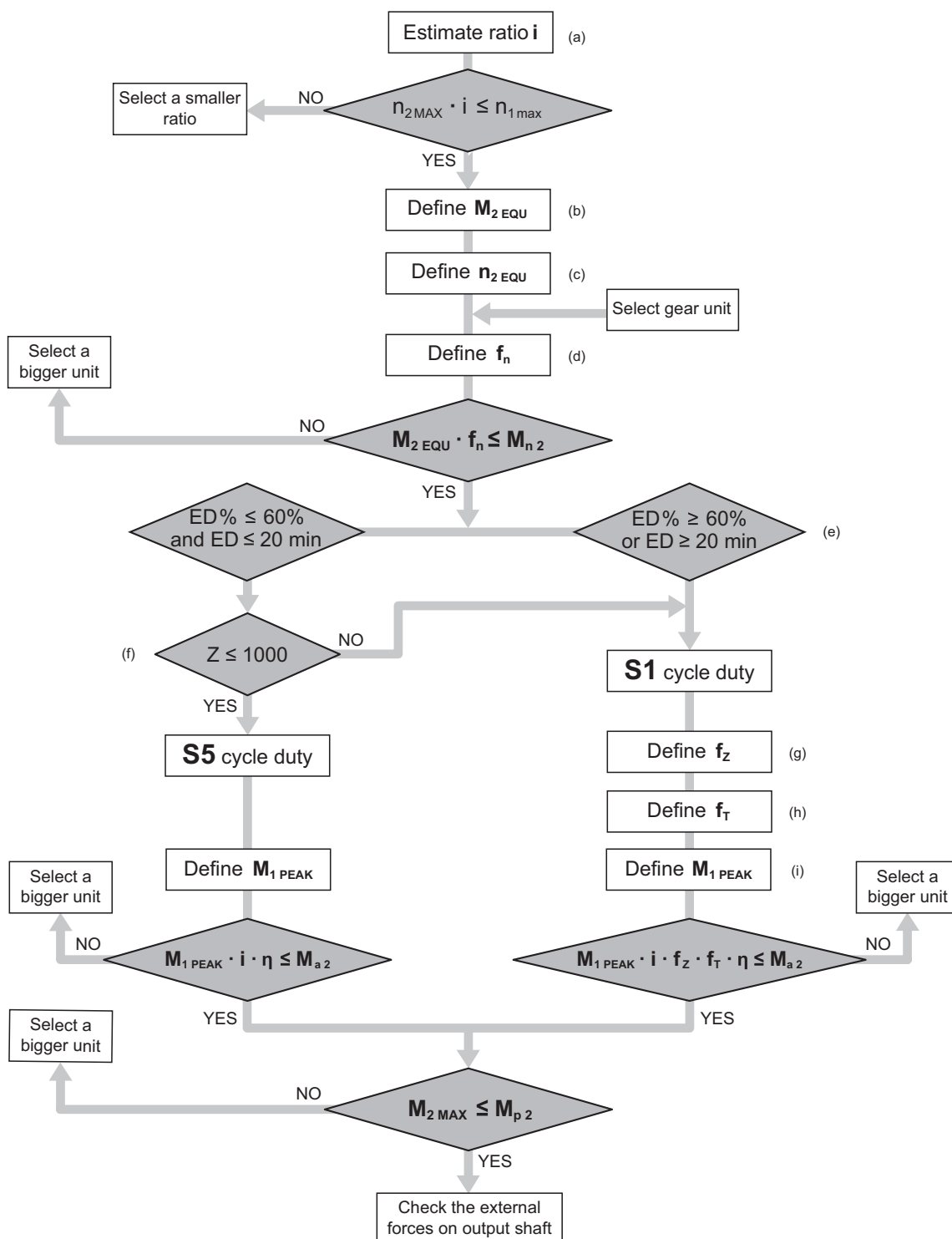
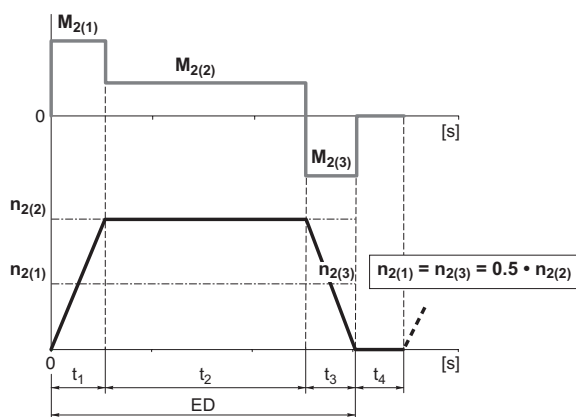

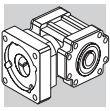

## 2 FEATURES OF KR SERIES

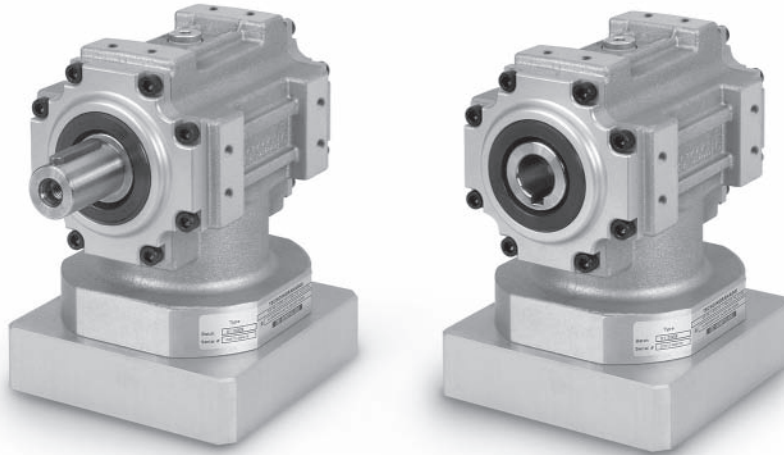

Distribution of nominal torque		$M_{n2}$ [Nm]		
	[i]	1	2	5
<b>KR 010</b>		10	7	3
<b>KR 020</b>		24	15	10
<b>KR 030</b>		55	37	22
<b>KR 040</b>		120	85	45

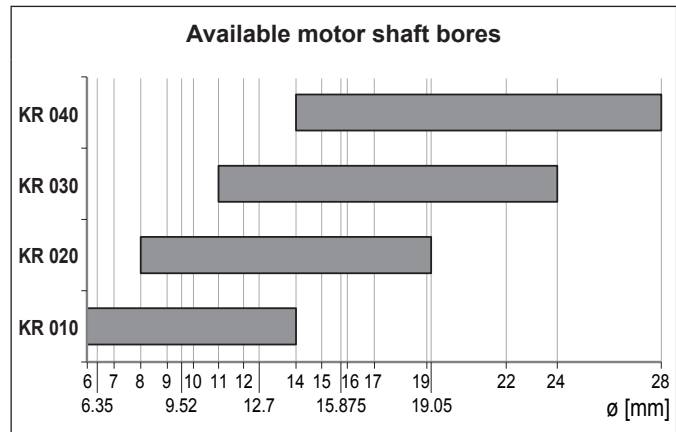

Bevel helical units type KR, manufactured under the most stringent quality specifications, are designed for dynamic and accurate applications where light weight and space effectiveness are a factor.

Many options can be selected from the catalogue as far as motor adapters and output shaft configurations that facilitate the installation on the driven equipment.

- Available in one only backlash option ( $\psi_s = 8'$ )
- Single reduction: ratios  $i = 1, 2, 5$
- Radial ball bearings (SB) are of standard supply, while taper roller bearings (HB) can be optionally specified for particularly demanding loading conditions
- Degree of protection IP65
- Oil seals from Viton® compound as standard
- Max. noise level  $L_P \leq 70$  dB(A) @  $n_1 = 3000$  min<sup>-1</sup>
- Units are factory charged with synthetic lubricant suitable for operation at ambient temperatures in the range 0°...40°C. The lubricant quantity is affected by mounting position, that therefore will have to be specified at the time of ordering. In the absence of contamination lubricant does not require periodical changes.

The type of lubricant, whether grease or oil, depends on type of duty, as charted below:

duty	KR 010 ... KR 040
<b>S1</b> (continuous)	synthetic oil viscosity ISO VG 220
<b>S5</b> (intermittent)	NLGI grease consistency 00



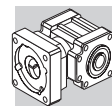

## 2.1 VERSIONS

### Parallel shaft

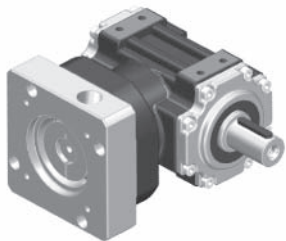
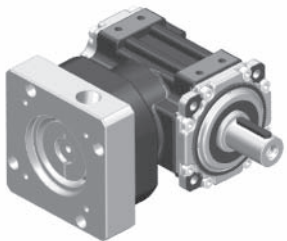
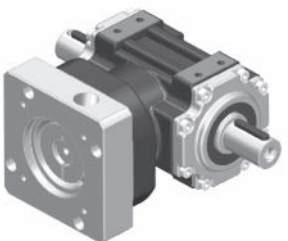
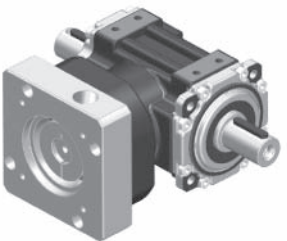
LP	LPF	LD	LDF
			
single extension	single extension + flange	double extension	double extension + flange

### Hollow shaft

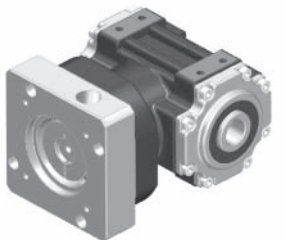
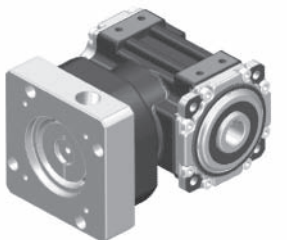
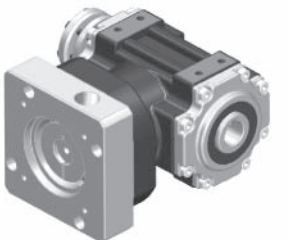
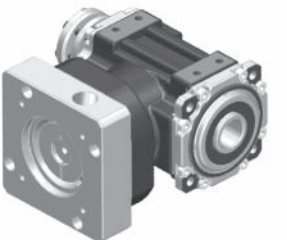
H	HF	S	SF
			
keyed (KR 030...KR 040)	keyed shaft + flange (KR 030...KR 040)	with shrink disc	with shrink disc + flange

## 2.2 MOUNTING POSITIONS

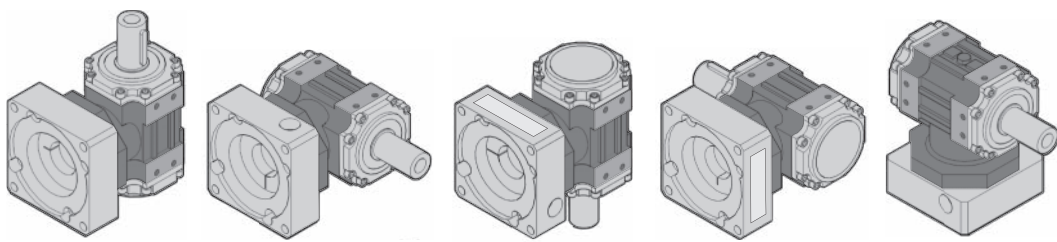
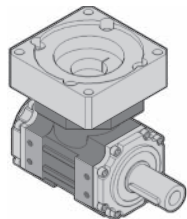
U	VA
	

## 2.3 COORDINATED SHAFT ROTATION

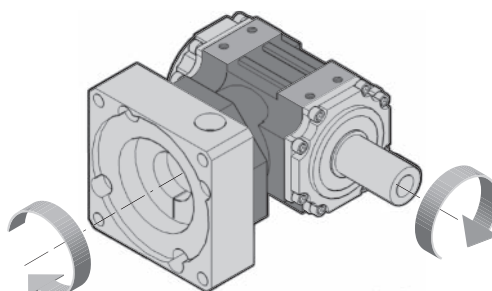

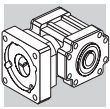

### 3 ORDERING CODE

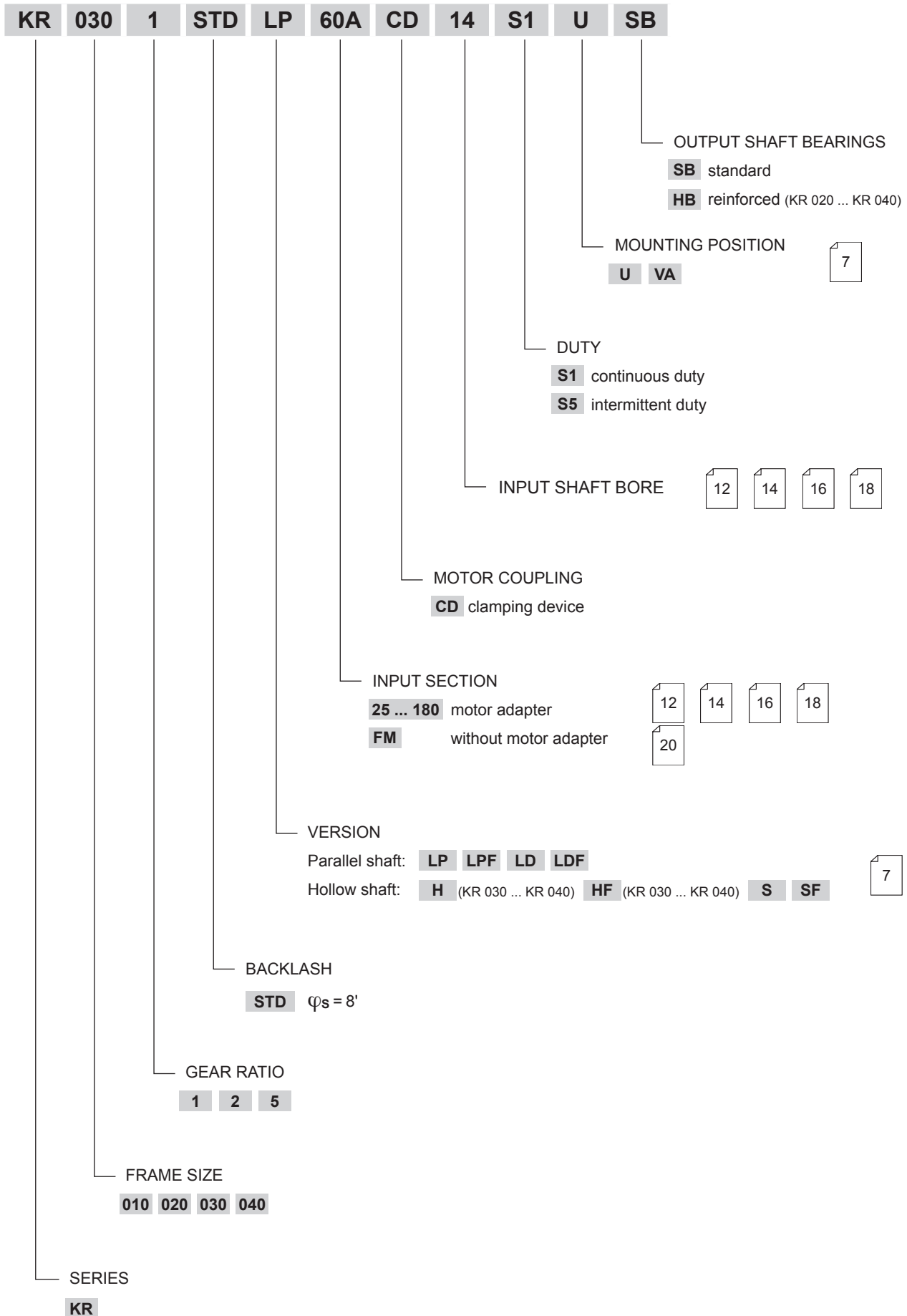

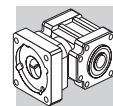

#### 4 TECHNICAL SPECIFICATIONS







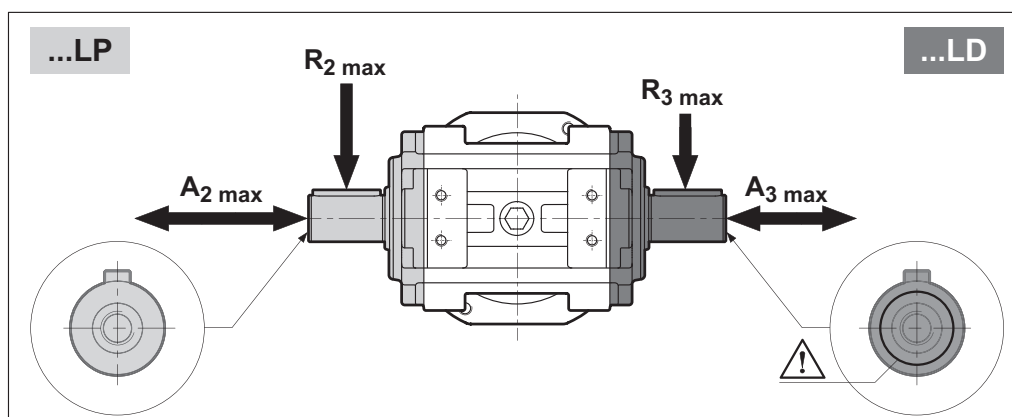

KR 010						
	$M_{n2}$ [Nm]	$M_{a2}$ [Nm]	$M_{p2}$ [Nm]	$n_{1\max}$ [min <sup>-1</sup> ]	$\varphi_s$ [arcmin]	$\eta$ %
<b>i = 1</b>	10	14	20	4000		
<b>i = 2</b>	7	10	15	5000	8'	97
<b>i = 5</b>	3	4	6	5000		

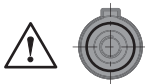
KR 020						
	$M_{n2}$ [Nm]	$M_{a2}$ [Nm]	$M_{p2}$ [Nm]	$n_{1\max}$ [min <sup>-1</sup> ]	$\varphi_s$ [arcmin]	$\eta$ %
<b>i = 1</b>	24	35	50	4000		
<b>i = 2</b>	15	21	30	5000	8'	97
<b>i = 5</b>	10	13	20	5000		

KR 030						
	$M_{n2}$ [Nm]	$M_{a2}$ [Nm]	$M_{p2}$ [Nm]	$n_{1\max}$ [min <sup>-1</sup> ]	$\varphi_s$ [arcmin]	$\eta$ %
<b>i = 1</b>	55	75	110	3500		
<b>i = 2</b>	37	52	75	4500	8'	97
<b>i = 5</b>	22	29	45	4500		

KR 040						
	$M_{n2}$ [Nm]	$M_{a2}$ [Nm]	$M_{p2}$ [Nm]	$n_{1\max}$ [min <sup>-1</sup> ]	$\varphi_s$ [arcmin]	$\eta$ %
<b>i = 1</b>	120	170	240	3500		
<b>i = 2</b>	85	120	170	4500	8'	97
<b>i = 5</b>	45	60	90	4500		



							
		$R_{2\max}$ [N]	$A_{2\max}$ [N]	$A_{2'\max}$ [N]	$R_{3\max}$ [N]	$A_{3\max}$ [N]	$A_{3'\max}$ [N]
KR 010	SB 	1000	—	200	500	—	100
	HB 	1500	—	300	750	—	150
KR 020	SB 	3000	1500	600	3000	1500	600
	HB 	2000	—	400	1000	—	200
KR 030	SB 	4000	2000	800	4000	2000	800
	HB 	3000	—	600	1500	—	300
KR 040	SB 	5500	2750	1100	5500	2750	1100
	HB 						

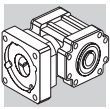

## 5 MASS MOMENT OF INERTIA

### 5.1 KR 010...KR 040 with standard ball bearings - SB

KR 010			
		$J_G$ [kgcm <sup>2</sup> ]	
		$6 \leq D \leq 9.52$	$10 \leq D \leq 14$
$i = 1$	S, SF	0.52	0.52
	LP, LPF	0.38	0.38
	LD, LDF	0.39	0.39
$i = 2$	S, SF	0.27	0.29
	LP, LPF	0.24	0.25
	LD, LDF	0.24	0.25
$i = 5$	S, SF	0.20	0.21
	LP, LPF	0.19	0.21
	LD, LDF	0.19	0.21

KR 020			
		$J_G$ [kgcm <sup>2</sup> ]	
		$8 \leq D \leq 12.7$	$14 \leq D \leq 19.05$
$i = 1$	S, SF	1.61	1.80
	LP, LPF	1.34	1.52
	LD, LDF	1.37	1.55
$i = 2$	S, SF	0.86	1.05
	LP, LPF	0.80	0.98
	LD, LDF	0.80	0.99
$i = 5$	S, SF	0.66	0.84
	LP, LPF	0.64	0.83
	LD, LDF	0.65	0.83

KR 030				
		$J_G$ [kgcm <sup>2</sup> ]		
		$11 \leq D \leq 12.7$	$14 \leq D \leq 19$	$22 \leq D \leq 24$
$i = 1$	H, HF	4.37	4.45	4.64
	S, SF	5.00	5.08	5.27
	LP, LPF	4.70	4.78	4.97
	LD, LDF	4.63	4.71	4.90
$i = 2$	H, HF	2.04	2.12	2.31
	S, SF	2.20	2.28	2.47
	LP, LPF	2.12	2.20	2.39
	LD, LDF	2.11	2.19	2.37
$i = 5$	H, HF	1.47	1.55	1.74
	S, SF	1.50	1.57	1.76
	LP, LPF	1.48	1.56	1.75
	LD, LDF	1.48	1.56	1.75

KR 040				
		$J_G$ [kgcm <sup>2</sup> ]		
		$14 \leq D \leq 19$	$22 \leq D \leq 24$	$D = 28$
$i = 1$	H, HF	17.19	17.37	17.77
	S, SF	20.46	20.65	21.05
	LP, LPF	18.21	18.40	18.80
	LD, LDF	18.90	19.08	19.48
$i = 2$	H, HF	4.47	4.65	5.06
	S, SF	5.29	5.47	5.87
	LP, LPF	4.73	4.91	5.31
	LD, LDF	4.90	5.08	5.48
$i = 5$	H, HF	5.23	5.42	5.82
	S, SF	5.36	5.55	5.95
	LP, LPF	5.27	5.46	5.86
	LD, LDF	5.30	5.49	5.89

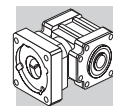

## 5.2 KR 020...KR 040 with taper roller bearings - HB

KR 020			
		J <sub>G</sub> [kgcm <sup>2</sup> ]	
		D	
HB 		8 ≤ D ≤ 12.7	14 ≤ D ≤ 19.05
i = 1	S, SF	1.87	2.06
	LP, LPF	1.60	1.78
	LD, LDF	1.62	1.81
i = 2	S, SF	0.93	1.12
	LP, LPF	0.86	1.05
	LD, LDF	0.87	1.05
i = 5	S, SF	0.67	0.85
	LP, LPF	0.66	0.84
	LD, LDF	0.66	0.84

KR 030				
		J <sub>G</sub> [kgcm <sup>2</sup> ]		
		D		
HB 		11 ≤ D ≤ 12.7	14 ≤ D ≤ 19	22 ≤ D ≤ 24
i = 1	H, HF	5.48	5.56	5.75
	S, SF	6.11	6.19	6.38
	LP, LPF	5.81	5.89	6.08
	LD, LDF	5.74	5.82	6.01
i = 2	H, HF	2.92	3.00	3.19
	S, SF	3.08	3.16	3.35
	LP, LPF	3.01	3.09	3.27
	LD, LDF	2.99	3.07	3.26
i = 5	H, HF	1.51	1.59	1.78
	S, SF	1.54	1.62	1.81
	LP, LPF	1.53	1.61	1.80
	LD, LDF	1.53	1.60	1.79

KR 040				
		J <sub>G</sub> [kgcm <sup>2</sup> ]		
		D		
HB 		14 ≤ D ≤ 19	22 ≤ D ≤ 24	D = 28
i = 1	H, HF	18.82	19.01	19.41
	S, SF	22.10	22.28	22.69
	LP, LPF	19.85	20.04	20.44
	LD, LDF	20.53	20.72	21.12
i = 2	H, HF	4.88	5.06	5.47
	S, SF	5.70	6.28	6.28
	LP, LPF	5.13	5.72	5.72
	LD, LDF	5.31	5.89	5.89
i = 5	H, HF	5.30	5.48	5.89
	S, SF	5.43	6.02	6.02
	LP, LPF	5.34	5.93	5.93
	LD, LDF	5.37	5.95	5.95

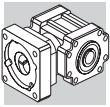

# KR 010

## 6 DIMENSIONS

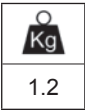
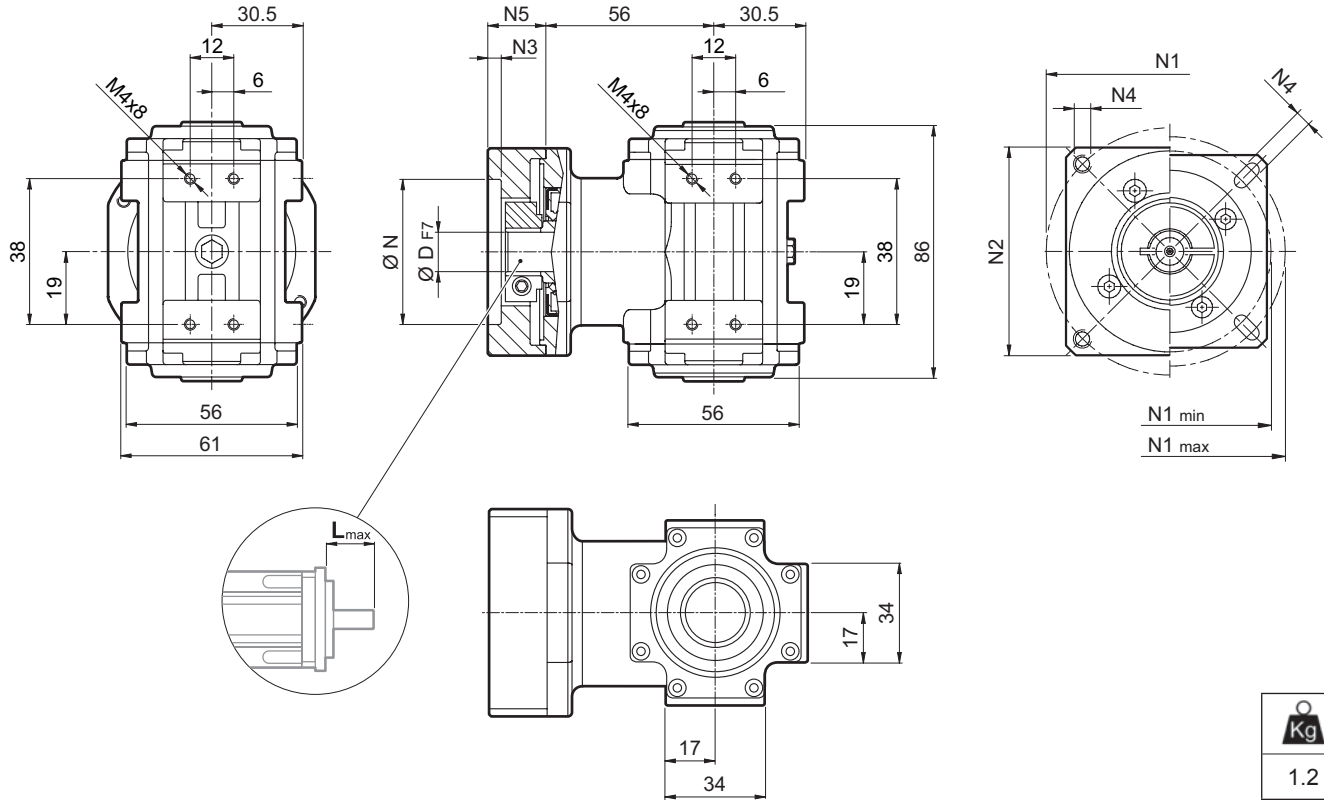

												N	N1		N2	N3	N4	N5	L <sub>max</sub>
	min	max																	
25AH	6	6.35	7	8	9	9.52	-	-	-	-	-	25	39	56					
26AH	6	6.35	7	8	9	9.52	-	-	-	-	-	26	39	56					
28AH	6	6.35	7	8	9	9.52	-	-	-	-	-	28	39	56					
30AH	6	6.35	7	8	9	9.52	-	-	-	-	-	30	39	56					
32AH	6	6.35	7	8	9	9.52	-	-	-	-	-	32	39	56	65	3.5	4.5	25	25
34AH	6	6.35	7	8	9	9.52	-	-	-	-	-	34	40	56					
36AH	6	6.35	7	8	9	9.52	-	-	-	-	-	36	42	56					
39AH	6	6.35	7	8	9	9.52	-	-	-	-	-	39	45	56					
40AH	6	6.35	7	8	9	9.52	-	-	-	-	-	40	46	56					
38B	6	6.35	7	8	9	9.52	10	11	12	12.7	-	38.1	66.6	60	60	3	M4x10	18	25
40B	6	6.35	7	8	9	9.52	10	11	12	12.7	-	40	63	60	60	3	M4x10	18	25
50A	6	6.35	7	8	9	9.52	10	11	12	12.7	-	50	60	60	60	3	M4x10	18	25
50B	6	6.35	7	8	9	9.52	10	11	12	12.7	14	50	65	60	60	3	M5x12	23	30
50BH	6	6.35	7	8	9	9.52	10	11	12	12.7	14	50	65	65	65	3	5.5	25	32
50C	6	6.35	7	8	9	9.52	10	11	12	12.7	14	50	70	60	60	3	M4x10	23	30
55MH	6	6.35	7	8	9	9.52	10	11	12	12.7	-	55	80	65	65	2	5.5	16	23
60A	6	6.35	7	8	9	9.52	10	11	12	12.7	-	60	75	63	63	3	M5x12	18	25
60A1	6	6.35	7	8	9	9.52	10	11	12	12.7	14	60	75	63	63	3	M5x12	23	30
60B	6	6.35	7	8	9	9.52	10	11	12	12.7	14	60	85	75	75	3	M5x12	23	30
60C	6	6.35	7	8	9	9.52	10	11	12	12.7	14	60	90	75	75	3	M5x12	23	30
70A	6	6.35	7	8	9	9.52	10	11	12	12.7	14	70	85	75	75	3	M6x15	23	30
70B	6	6.35	7	8	9	9.52	10	11	12	12.7	14	70	90	75	75	3	M5x12	23	30
73A	6	6.35	7	8	9	9.52	10	11	12	12.7	14	73	98.4	85	85	3	M5x12	25	32
80A	6	6.35	7	8	9	9.52	10	11	12	12.7	14	80	100	85	85	3	M6x15	23	30

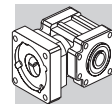

## KR 010... S

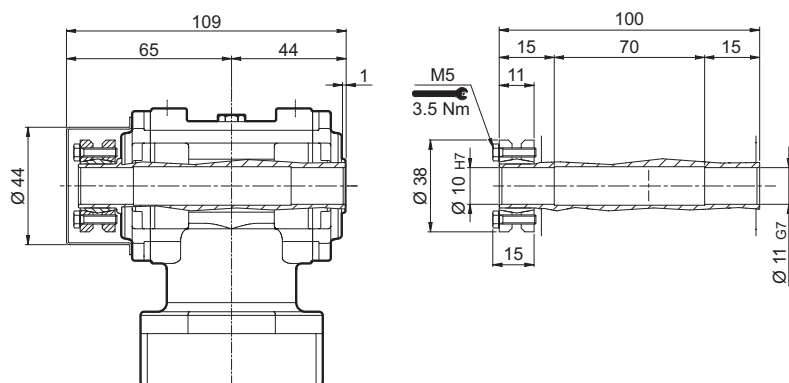

## KR 010... SF

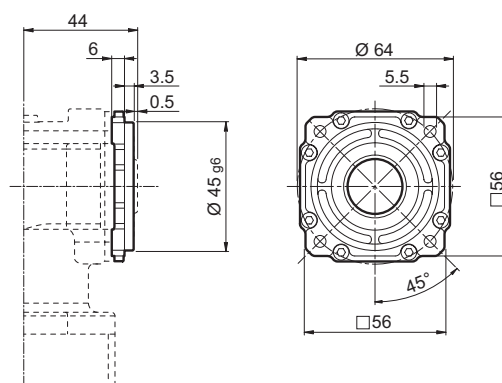

## KR 010... LP

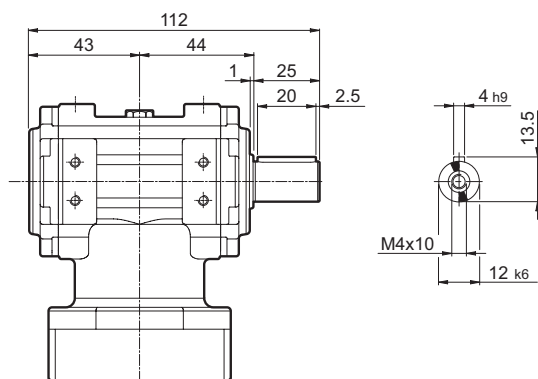

## KR 010... LPF

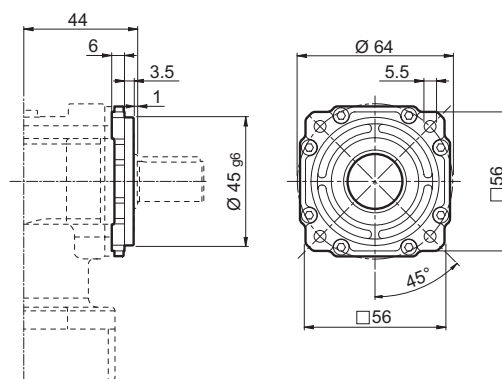

## KR 010... LD

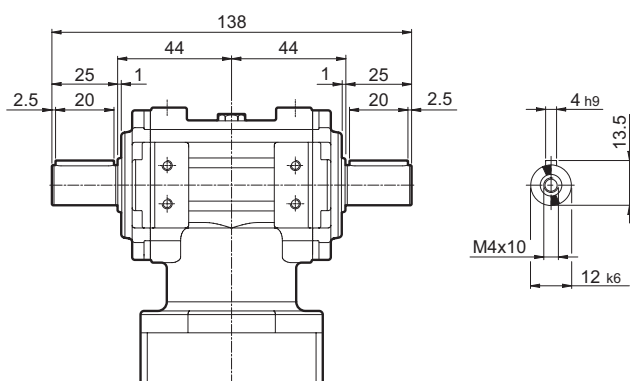

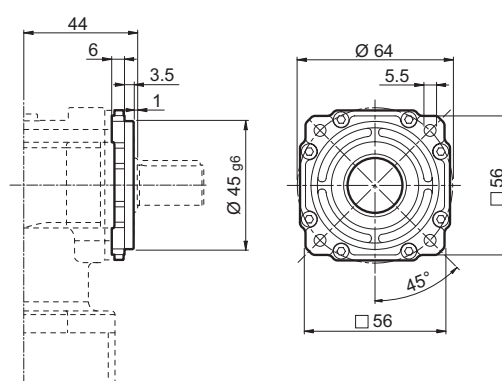

## KR 010... LDF

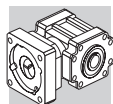

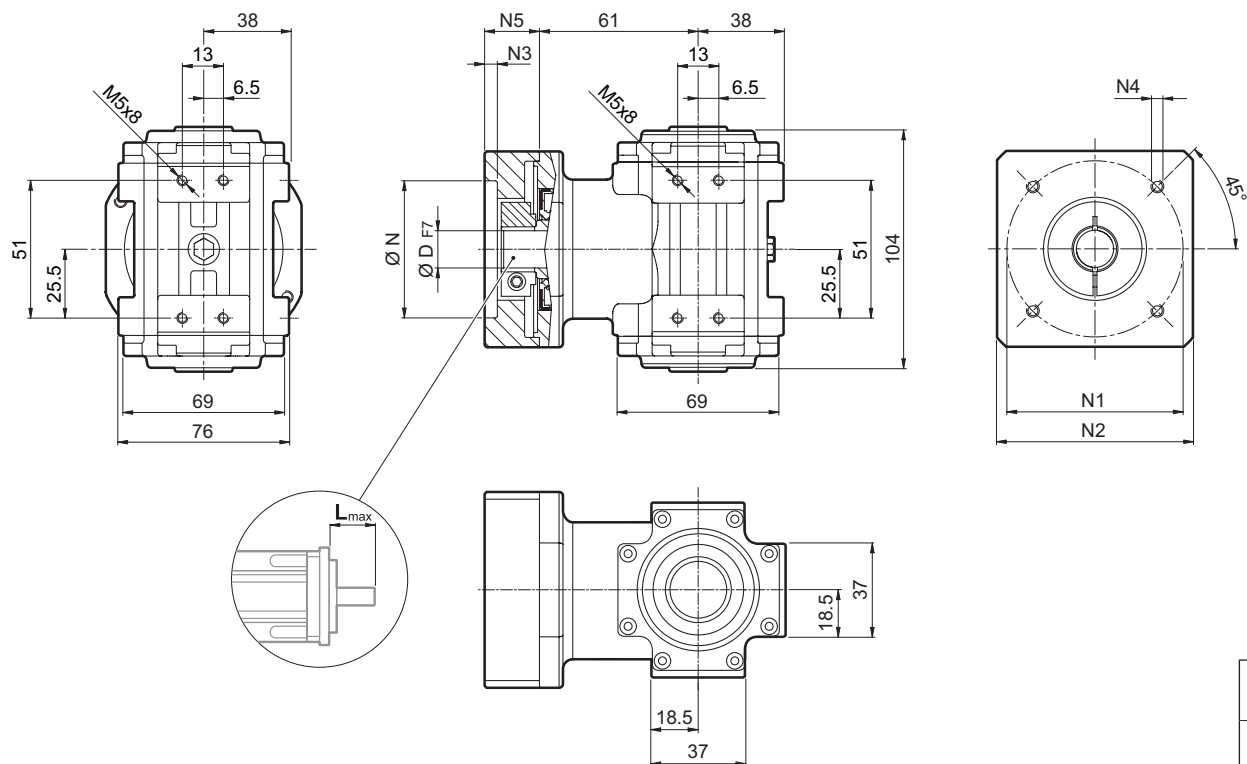

# KR 020



												N	N1	N2	N3	N4	N5	L <sub>max</sub>	
<b>40B1</b>	8	9	9.52	11	12	12.7	14	-	-	-	-	40	63	80	4	M4x10	34	40	
<b>45A</b>	8	9	9.52	11	12	12.7	-	-	-	-	-	45	63	80	4	M4x10	34	40	
<b>50B1</b>	8	9	9.52	11	12	12.7	14	-	-	-	-	50	65	80	4	M5x16	34	40	
<b>50BH1</b>	8	9	9.52	11	12	12.7	14	-	-	-	-	50	65	80	4	5.5	34	40	
<b>50C1</b>	8	9	9.52	11	12	12.7	14	-	-	-	-	50	70	80	4	M4x10	34	40	
<b>50D</b>	8	9	9.52	11	12	12.7	14	-	-	-	-	50	95	80	4	M6x10	34	40	
<b>55A</b>	8	9	9.52	11	12	12.7	14	15.875	16	17	19	19.05	55.5	125.7	105	4	M6x16	34	40
<b>60A2</b>	8	9	9.52	11	12	12.7	14	-	-	-	-	60	75	80	4	M5x16	34	40	
<b>60AH2</b>	8	9	9.52	11	12	12.7	14	-	-	-	-	60	75	90	4	5.5	34	40	
<b>60B1</b>	8	9	9.52	11	12	12.7	14	15.875	16	-	-	60	85	80	4	M5x16	34	40	
<b>60C1</b>	8	9	9.52	11	12	12.7	14	15.875	16	-	-	60	90	80	4	M5x16	34	40	
<b>70A1</b>	8	9	9.52	11	12	12.7	14	15.875	16	17	19	19.05	70	85	80	4	M6x20	34	40
<b>70AH1</b>	8	9	9.52	11	12	12.7	14	15.875	16	17	19	19.05	70	85	90	4	6.5	34	40
<b>70B1</b>	8	9	9.52	11	12	12.7	14	15.875	16	17	19	19.05	70	90	80	4	M5x16	34	40
<b>73A1</b>	8	9	9.52	11	12	12.7	14	-	-	-	-	73	98.4	85	4	M5x16	34	40	
<b>80A1</b>	8	9	9.52	11	12	12.7	14	15.875	16	17	19	19.05	80	100	90	4	M6x16	34	40
<b>95A</b>	8	9	9.52	11	12	12.7	14	15.875	16	17	19	19.05	95	115	100	4	M8x20	34	40
<b>95B</b>	8	9	9.52	11	12	12.7	14	15.875	16	17	19	19.05	95	130	115	4	M8x20	34	40
<b>110A</b>	8	9	9.52	11	12	12.7	14	15.875	16	17	19	19.05	110	130	115	4	M8x20	34	40
<b>110B</b>	8	9	9.52	11	12	12.7	14	15.875	16	17	19	19.05	110	145	120	6.5	M8x20	44	50
<b>110B1</b>	8	9	9.52	11	12	12.7	14	15.875	16	17	19	19.05	110	145	120	6.5	M8x20	54	60



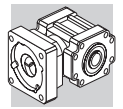

## KR 020... S

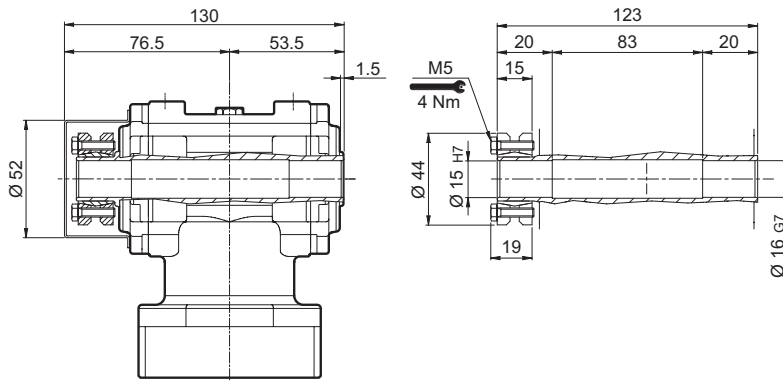

## KR 020... SF

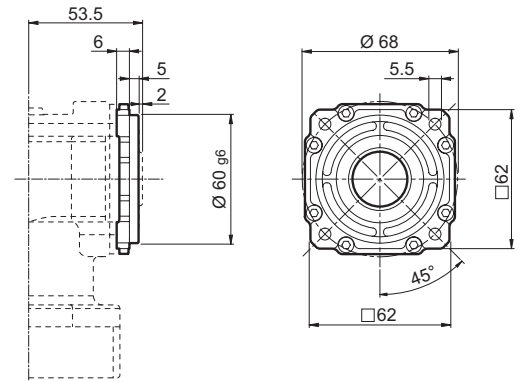

## KR 020... LP

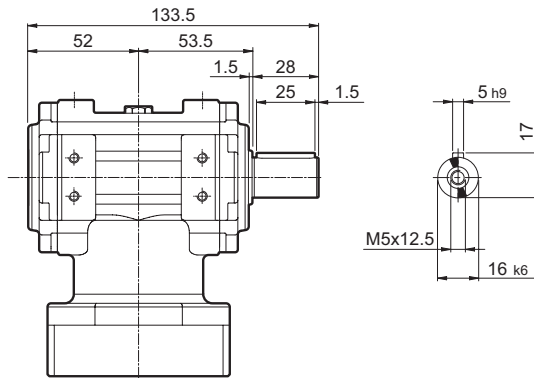

## KR 020... LPF

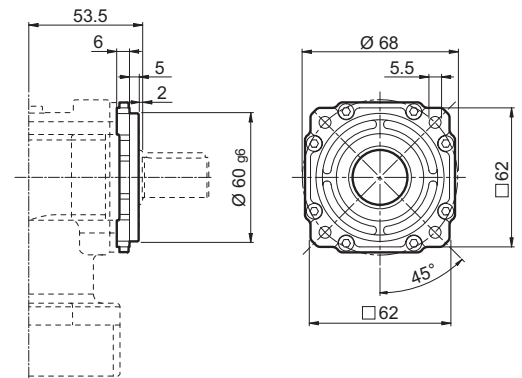

## KR 020... LD

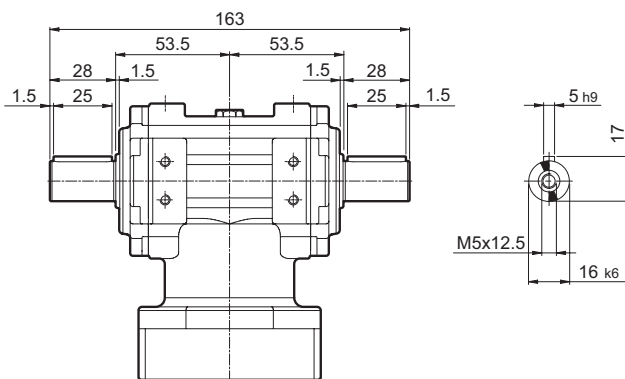

## KR 020... LDF

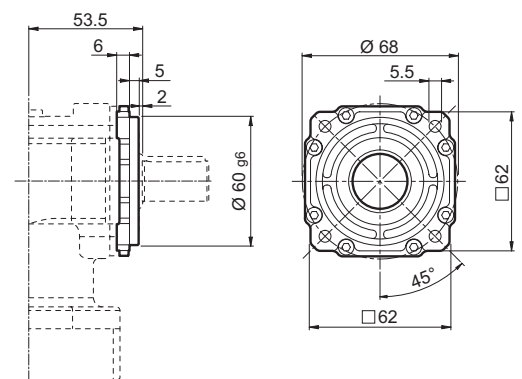

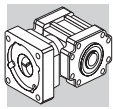

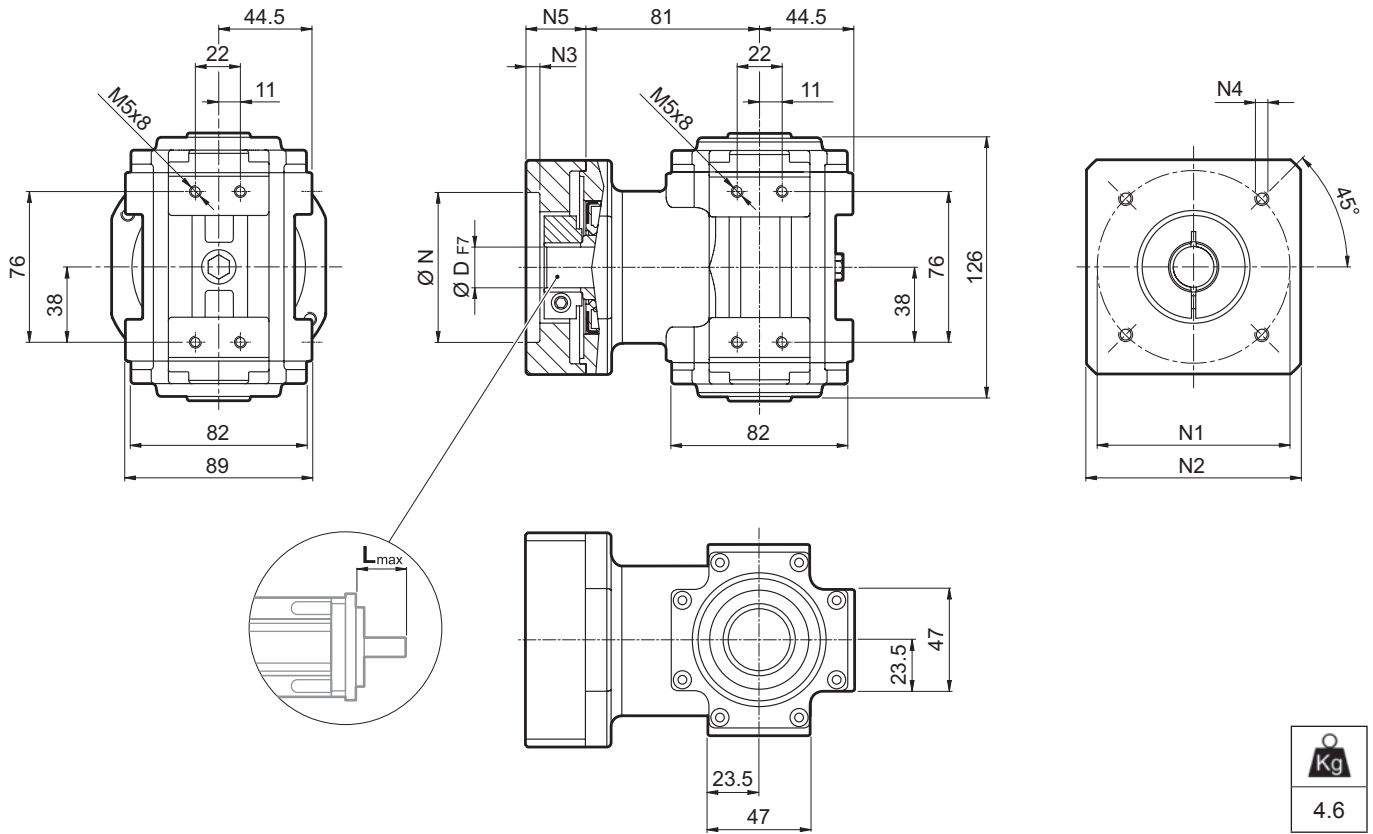

# KR 030



**Kg**  
4.6

											N	N1	N2	N3	N4	N5	L <sub>max</sub>
<b>50D</b>	11	12	12.7	14	15	15.875	16	19	-	-	50	95	100	5	M6x14	28	40
<b>55A</b>	11	12	12.7	14	15	15.875	16	19	-	-	55.5	125.7	105	5	M6x16	28	40
<b>60A2</b>	11	12	12.7	14	15	15.875	16	19	-	-	60	75	100	5	M5x14	28	40
<b>60AH2</b>	11	12	12.7	14	15	15.875	16	19	-	-	60	75	100	5	6.5	33	40
<b>60B1</b>	11	12	12.7	14	15	15.875	16	19	-	-	60	85	100	6.5	M5x14	28	40
<b>70A1</b>	11	12	12.7	14	15	15.875	16	19	-	-	70	85	100	5	M6x14	28	40
<b>70AH1</b>	11	12	12.7	14	15	15.875	16	19	-	-	70	85	100	5	6	33	40
<b>70B1</b>	11	12	12.7	14	15	15.875	16	19	-	-	70	90	100	5	M5x12	28	40
<b>80A1</b>	11	12	12.7	14	15	15.875	16	19	-	-	80	100	100	5	M6x16	28	40
<b>80AH1</b>	11	12	12.7	14	15	15.875	16	19	-	-	80	100	100	5	6.5	28	40
<b>95A</b>	11	12	12.7	14	15	15.875	16	19	-	-	95	115	100	5	M8x18	28	40
<b>95A1</b>	11	12	12.7	14	15	15.875	16	19	22	24	95	115	100	5	M8x18	38	50
<b>95B</b>	11	12	12.7	14	15	15.875	16	19	-	-	95	130	115	5	M8x18	28	40
<b>110A</b>	11	12	12.7	14	15	15.875	16	19	-	-	110	130	115	5	M8x18	28	40
<b>110A1</b>	11	12	12.7	14	15	15.875	16	19	22	24	110	130	115	6.5	M8x20	38	50
<b>110B</b>	11	12	12.7	14	15	15.875	16	19	22	24	110	145	120	6.5	M8x20	38	50
<b>110B1</b>	11	12	12.7	14	15	15.875	16	19	22	24	110	145	120	6.5	M8x20	48	60
<b>130A</b>	11	12	12.7	14	15	15.875	16	19	22	24	130	165	140	6.5	M10x20	38	50
<b>130A1</b>	11	12	12.7	14	15	15.875	16	19	22	24	130	165	140	6.5	M10x25	48	60

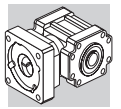

## KR 030... H

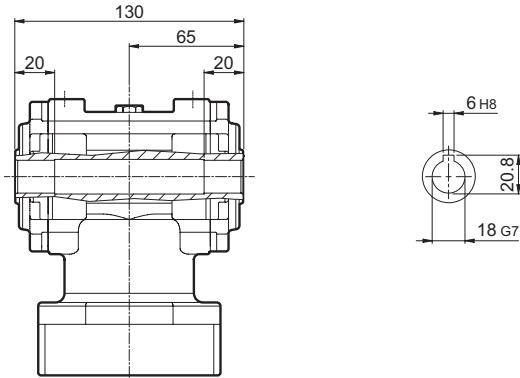

## KR 030... HF

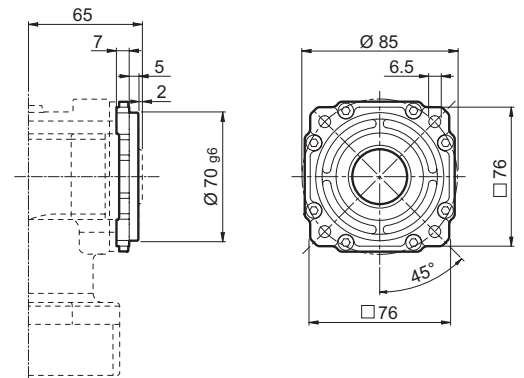

## KR 030... S

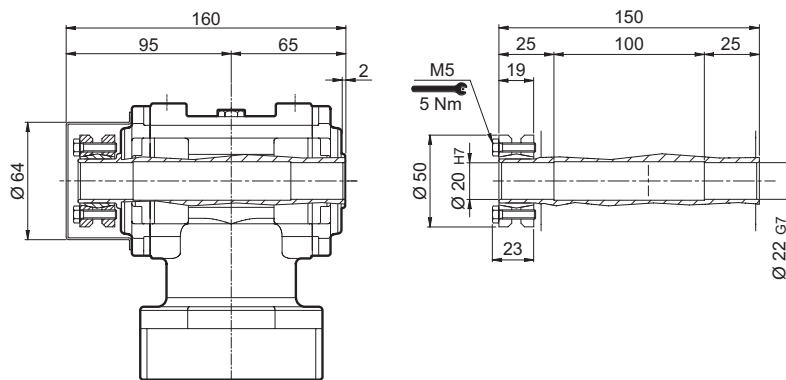

## KR 030... SF

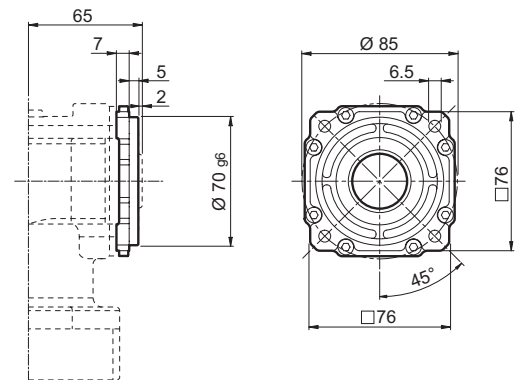

## KR 030... LP

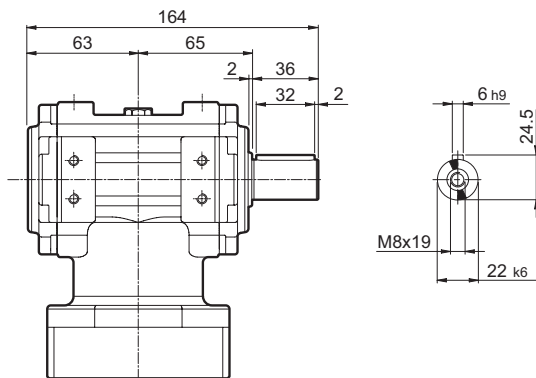

## KR 030... LPF

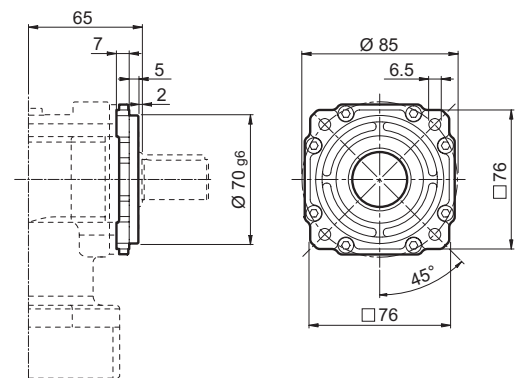

## KR 030... LD

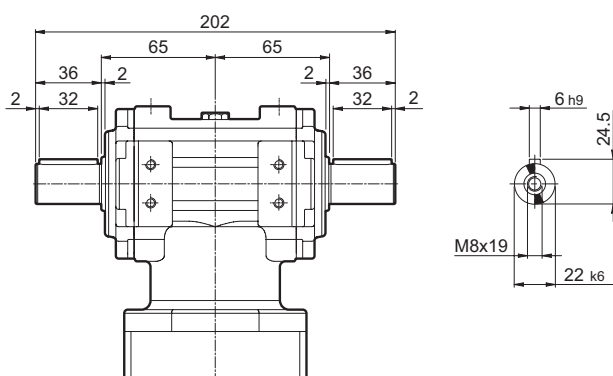

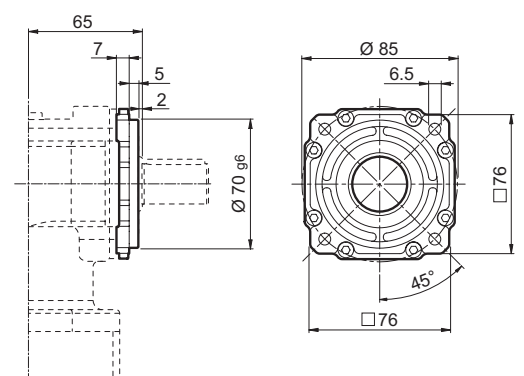

## KR 030... LDF

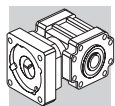

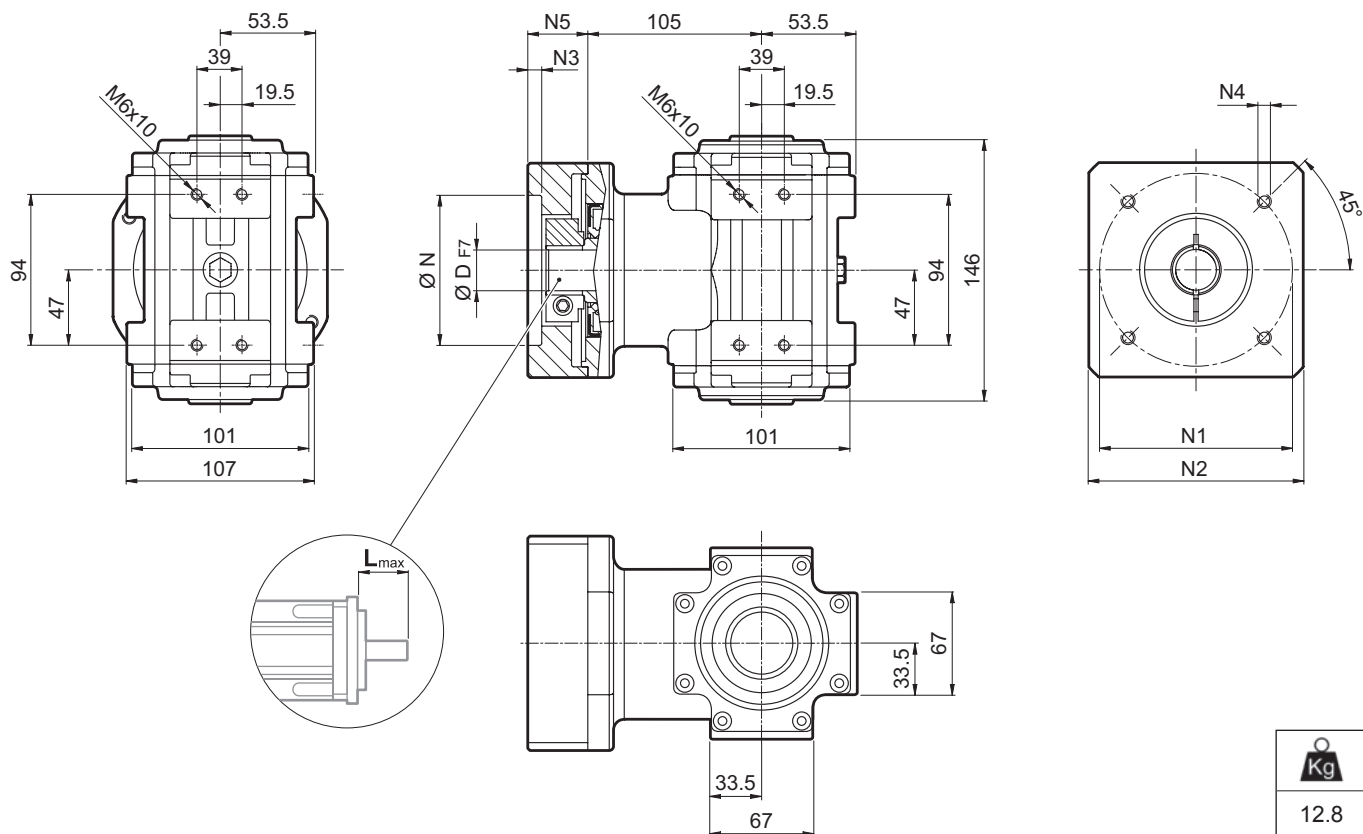

# KR 040



								N	N1	N2	N3	N4	N5	L <sub>max</sub>
	14	15.875	16	19	-	-	-							
<b>55A1</b>	14	15.875	16	19	-	-	-	55.5	125.7	130	4	M6x15	39.5	50
<b>80A2</b>	14	15.875	16	19	-	-	-	80	100	130	4	M6x15	39.5	50
<b>95A1</b>	14	15.875	16	19	22	24	-	95	115	130	4	M8x20	39.5	50
<b>110A1</b>	14	15.875	16	19	22	24	-	110	130	130	4	M8x20	39.5	50
<b>110B1</b>	14	15.875	16	19	22	24	-	110	145	130	6.5	M8x20	49.5	60
<b>114A</b>	14	15.875	16	19	22	24	28	114.3	200	170	5.5	M12x25	69.5	80
<b>130A</b>	14	15.875	16	19	22	24	-	130	165	140	4	M10x20	39.5	50
<b>130A1</b>	14	15.875	16	19	22	24	28	130	165	140	4	M10x20	49.5	60
<b>180A</b>	14	15.875	16	19	22	24	28	180	215	190	5.5	M14x25	49.5	60
<b>180A1</b>	14	15.875	16	19	22	24	28	180	215	190	5.5	M14x25	69.5	80

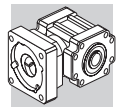

## KR 040... H

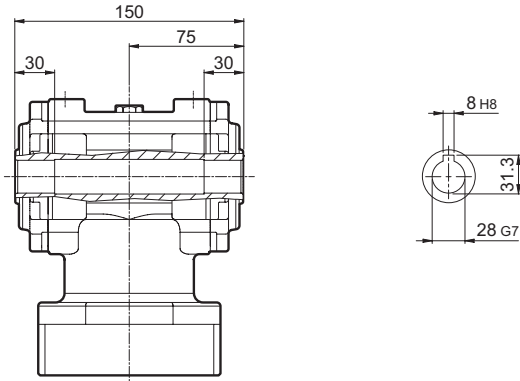

## KR 040... HF

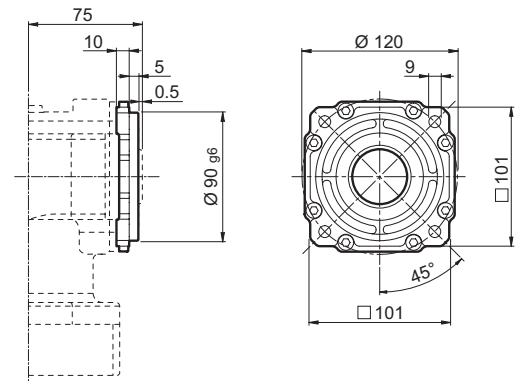

## KR 040... S

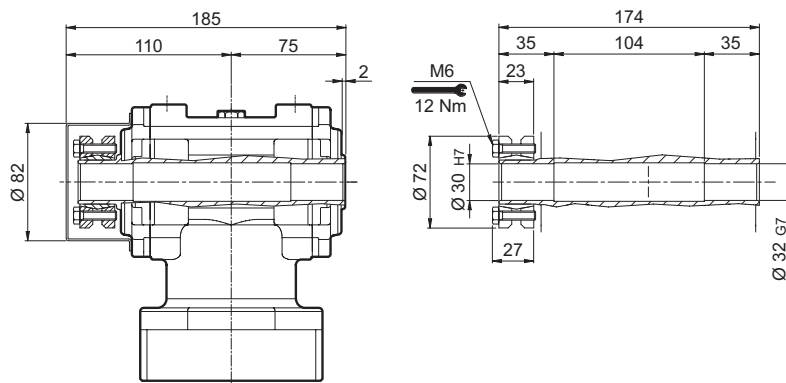

## KR 040... SF

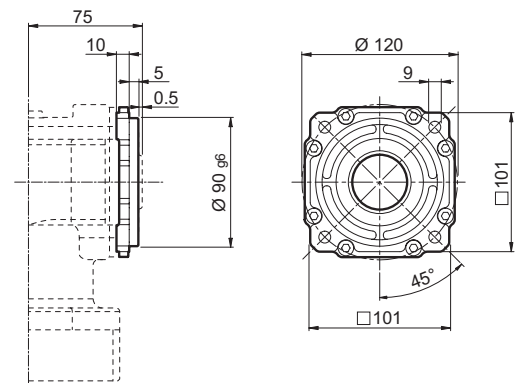

## KR 040... LP

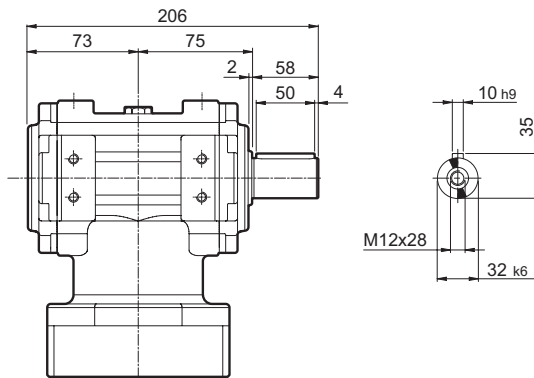

## KR 040... LPF

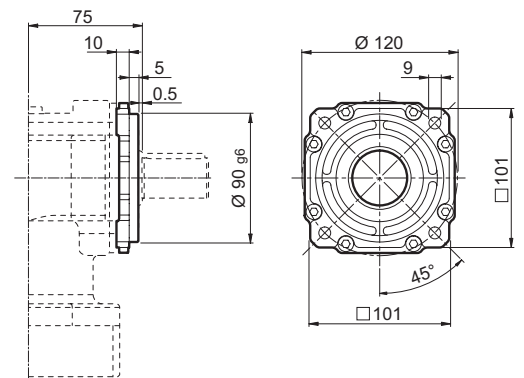

## KR 040... LD

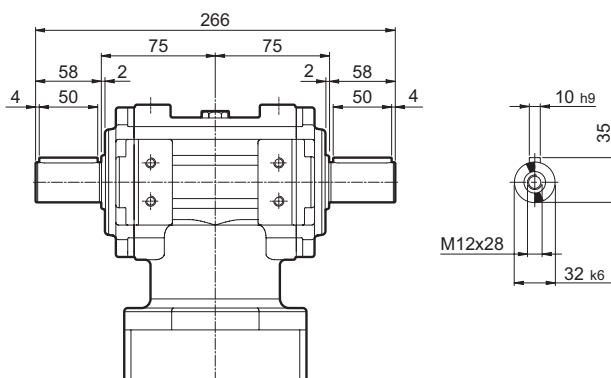

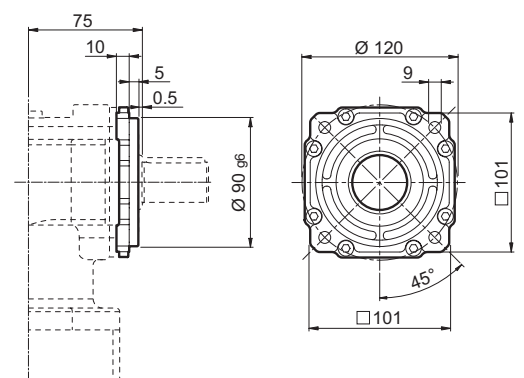

## KR 040... LDF

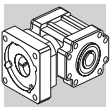

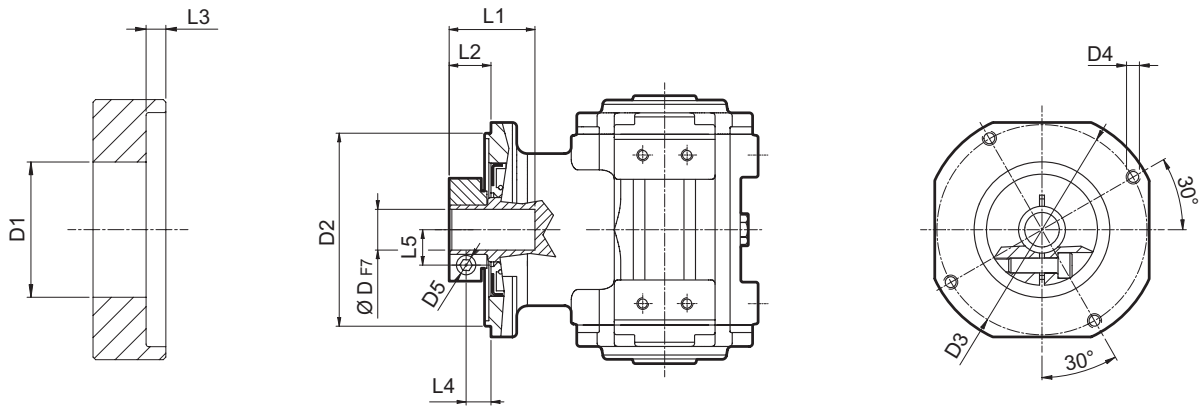

### 6.1 GEARBOX WITHOUT MOTOR ADAPTER - FM

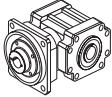

		D1	D2	D3	D4	D5	L1	L2	L3	L4	L5	
<b>KR 010</b>	6 6.35 7	32.5	50	42.5	M4x8	M4	28	13.5	3	8.5	8	1.0
	8 9 9.52 10	32.5	50	42.5	M4x8	M4	28	13.5	3	8.5	9	
	11 12 12.7	35.5	50	42.5	M4x8	M4	23	13.5	3	8.5	11	
	14	35.5	50	42.5	M4x8	M4	25	15.5	3	8.9	11.5	
<b>KR 020</b>	8 9 9.52	38	68	76.5	M6x10	M6	36.3	26.3	9.5	18.8	10.5	2.0
	11 12 12.7	43	68	76.5	M6x10	M6	36.3	26.3	9.5	18.8	12.5	
	14 15.875 16 17	48	68	76.5	M6x10	M6	36.3	26.3	9.5	18.8	14.5	
	19 19.05	51	68	76.5	M6x10	M6	36.3	26.3	9.5	18.8	16.5	
<b>KR 030</b>	11 12 12.7	43	90	98	M6x15	M6	35	19.5	7.6	12.1	12.5	3.5
	14 15 15.875 16	48	90	98	M6x15	M6	35	19.5	7.6	12.1	14.5	
	19	51	90	98	M6x15	M6	35	19.5	7.6	12.1	16.5	
	22 24	56.5	90	98	M6x15	M6	37	21.5	7.6	12.1	19	
<b>KR 040</b>	14 15.875 16	48	113	125.5	M8x15	M6	46	27.5	6	20	14.5	10.0
	19	51	113	125.5	M8x15	M6	46	27.5	6	20	16.5	
	22 24	56.5	113	125.5	M8x15	M6	47.5	29	6	20	19	
	28	67	113	125.5	M8x15	M8	47.5	29	6	20	22.5	

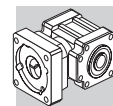



## 6.2 MACHINE SHAFT

Pivot of driven equipment should be made from high grade alloy steel. Table below shows recommended dimensions for the Customer to consider when designing mating shaft. A device retaining the shaft axially is also recommended (not shown). The number and size of relative tapped holes at shaft end depend on application requirements.

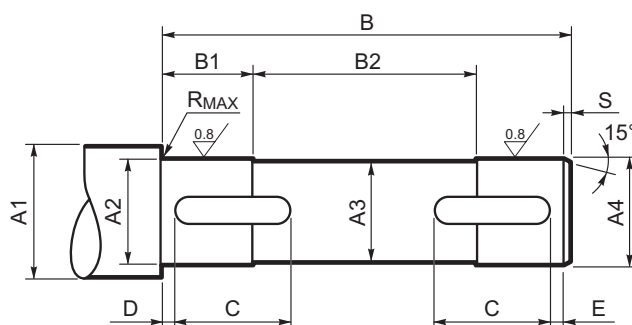
**H**

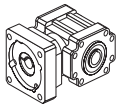

	A1	A2	A3	A4	B	B1	B2	C	D	E	R <sub>MAX</sub>	 UNI 6604	S
<b>KR 030</b>	≥ 26	18 h7	17	18 h7	129	18	90	32	2	2	0.5	6x6x25 A	1
<b>KR 040</b>	≥ 36	28 h7	27	28 h7	149	28	90	50	2	2	0.5	8x7x35 A	

NB: The choice of driven shaft with a UNI 6604 key as described introduces increased backlash into the application compared to that achieved by a configuration with just the gearbox ( $\varphi_s = 8^\circ$ ).

**S**

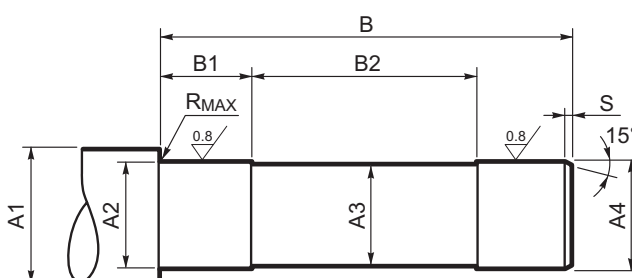

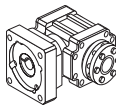
	A1	A2	A3	A4	B	B1	B2	R <sub>MAX</sub>	S
<b>KR 010</b>	≥ 15	11 h7	9.5	10 h6	99	13	70	0.5	1
<b>KR 020</b>	≥ 20	16 h7	14.5	15 h6	122	18	83	0.2	
<b>KR 030</b>	≥ 30	22 h7	19.5	20 h6	149	23	100	0.5	
<b>KR 040</b>	≥ 40	32 h7	29.5	30 h6	173	33	104	0.5	

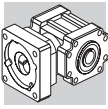

## INDEX OF REVISIONS (R)

R4	
	Description
14	Sect. 6 "Dimensions": - updated availability of motor shaft bores for input flange 40B
12 ... 20	Sect. 6 "Dimensions": - updated dimensions

120208

This publication supersedes and replaces any previous edition and revision. We reserve the right to implement modifications without notice.  
This catalogue cannot be reproduced, even partially, without prior consent.







Bonfiglioli has been designing and developing innovative and reliable power transmission and control solutions for industry, mobile machinery and renewable energy applications since 1956.